

MSP430 Internet Connectivity

Andreas Dannenberg

MSP430

ABSTRACT

Computer communication systems and especially the Internet are playing a rapidly increasingly important role in our everyday environment. But today this is not only a domain of personal computers or workstations. More and more, it makes its way to smaller network nodes, too. Imagine applications that are able to control hardware via a standard Internet browser, to transmit and visualize the state of sensors or automatically generate and send E-mails on the occurrence of special events (for example, for security purposes).

This application report describes in detail the implementation of an embedded Web server based on the MSP430 ultralow-power microcontroller series from Texas Instruments. The solution consists of both hardware (schematic, parts list) and software (C source). An ethernet LAN controller offers the physical connection to the Internet. A downsized TCP/IP protocol stack is used. Its functionality is encapsulated by an easy-to-use application programming interface (API). By using this API, creating new applications or modifying existing ones becomes an easy task. As an application example, a dynamic HTTP server is implemented.

Contents

1	Introduction	3
2	Important Protocol Basics	3
	2.1 Ethernet.....	4
	2.2 Address Resolution Protocol	5
	2.3 Internet Protocol.....	5
	2.4 Internet Control Message Protocol.....	6
	2.5 Transmission Control Protocol	6
	2.6 Hypertext Transfer Protocol.....	7
3	Hardware Description.....	7
	3.1 Interfacing to the LAN Controller	8
	3.2 Circuit Description.....	9
	3.3 Connection to the Network	10
4	Software Description.....	11

Amiga is a trademark of Amiga, Inc.

Apple and Macintosh are trademarks of Apple Computer, Inc.

Athlon is a trademark of Advanced Micro Devices, Inc.

Cassiopeia is a trademark of Casio Keisanki Kabushiki Kaisha DBA Casio Computer Co., Ltd., Japan

Crystal is a trademark of Crystal Semiconductor Corporation.

Cirrus is a trademark of Cirrus Logic, Inc.

Microsoft and Internet Explorer are a trademarks of Microsoft Corporation.

Netmon is a trademark of Systems Enhancement Corporation.

Netscape Navigator is a trademark of Netscape Communications Corporation.

Open Transport is a trademark of Information Management Company.

Pentium is a trademark of Intel Corporation.

Other trademarks are the property of their respective owners.

4.1	Ethernet Module	4
4.2	TCP/IP Module	4
4.2.1	Buffer Memory	4
4.2.2	Global Variables	4
4.2.3	Demultiplexing and Processing of Received Frames.....	4
4.2.4	Opening a Connection	4
4.2.5	Data Transfer	4
4.2.6	Closing a Connection	4
4.2.7	Using of Timers	4
4.2.8	Retransmission of Data.....	4
4.2.9	Summary	4
4.3	API.....	4
4.3.1	Functions	4
4.3.2	Flags	4
4.4	HTTP Server Application Example	4
4.4.1	Software Description	4
4.4.2	Dynamic Web Page Example	4
5	References	4
	Appendix A. Application Schematic	4
	Appendix B. Parts List.....	4

Figures

Figure 1.	ISO/OSI vs Internet Reference Model	3
Figure 2.	Data Encapsulation.....	4
Figure 3.	Hardware Block Diagram	4
Figure 4.	Prototype Board With Components Installed.....	4
Figure 5.	Using the Ethernet Module	4
Figure 6.	DoNetworkStuff() Flowchart	4
Figure 7.	Buffer Concept	4
Figure 8.	Demultiplexing of Received Frames	4
Figure 9.	Using DoNetworkStuff().....	4
Figure 10.	Transmitting of Data	4
Figure 11.	SocketStatus Register	4
Figure 12.	Data Reception	4
Figure 13.	Web Server Main Module	4
Figure 14.	Internet Explorer Screen	4

Tables

Table 1.	Functions of Internet Reference Model Layers	4
Table 2.	Important HTTP Methods	4
Table 3.	Overview of the Software Modules	4
Table 4.	Functions of the Ethernet Module.....	4
Table 5.	Compatible Communication Systems	4
Table 6.	Stack Error Codes.....	4

1 Introduction

While known for its use in PC networks, the ethernet also offers a robust, well-understood and reasonably priced technology for networking applications beyond the desktop computer. The goal of this design is to show how easy it is to implement a TCP/IP stack as well as an ethernet interface for the MSP430. It provides both a source code for the programmer as well as schematics for the design engineer.

It is advantageous if the reader of this application report has a general knowledge of TCP/IP networks and their related communication protocols. Section 2 contains some very basic information about the protocols used. For more detailed information, additional sources of information are mentioned. Sections 3 and 4 present both the hardware and software parts of the demonstration board featured in this application report.

Using the knowledge of this demonstration board, many applications are imaginable. Think of home automation, utility meters, appliances, security systems, card readers and building controls that can be easily controlled using either special front-end software or a comfortable Internet browser from anywhere around the world. The big advantage of an HTTP server in an embedded environment is that the web browser manages the whole user interface. The visualizing of information can be done simply by sending ASCII strings (HTML source) to the client and therefore minimal resources are required.

2 Important Protocol Basics

It is common to describe protocol stacks with a layered model. Each of these layers provides its own functions to upper level protocols and also uses help of lower level protocols to provide its services. The operational details of the lower layers are hidden from the higher layers. That simplifies both software design and maintenance. For example, a new transport layer using a different communication medium can be created, and it is not necessary to change the code of the upper layers. The reference model commonly used for describing the Internet architecture is a subset of the ISO/OSI seven-layer model. Figure 1 shows the relationship between these models and Table 1 the function of the different layers in the Internet reference model.

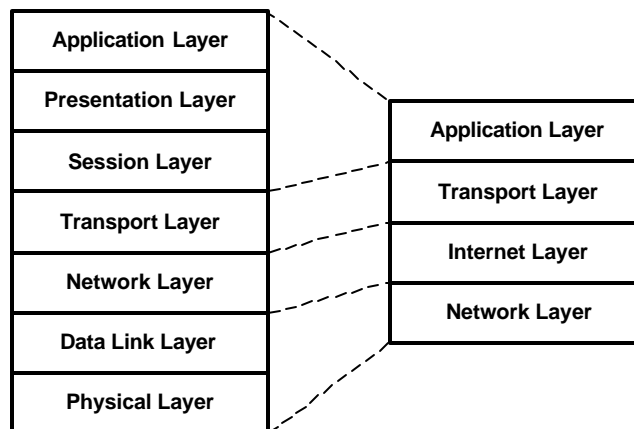
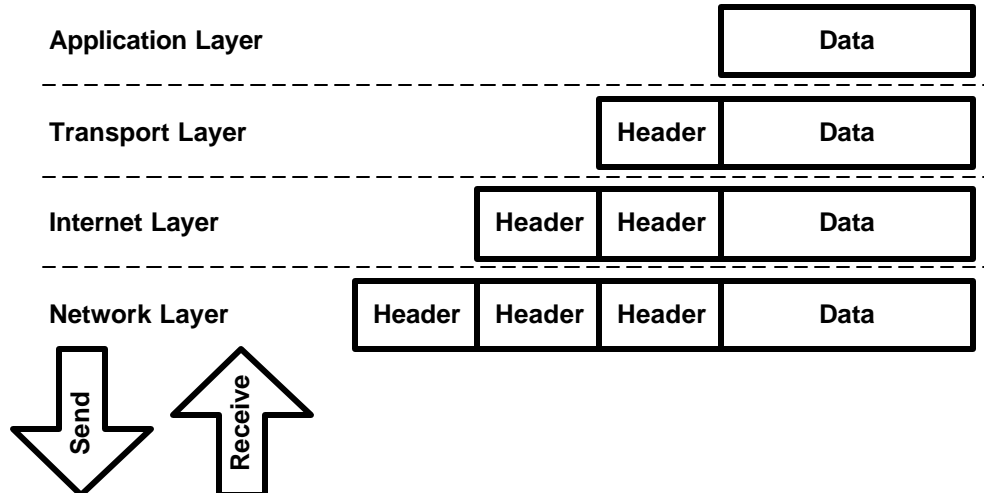

Figure 1. ISO/OSI vs Internet Reference Model

Table 1. Functions of Internet Reference Model Layers

Layer Name	Function	Example
Application layer	Contains a lot of protocols defined by different applications to provide their services.	HTTP, telnet, e-mail (SMTP, POP)
Transport layer	Makes the communication between endpoints possible.	Transmission control protocol (TCP), user datagram protocol (UDP)
Internet layer	Delivery and routing of datagrams between Internet nodes.	Internet protocol (IP), Internet control message protocol (ICMP), address resolution protocol (ARP)
Network layer	Host-specific implementation of transmission of datagrams.	Ethernet (IEEE 802.3), point-to-point protocol (PPP), AX.25

Beginning with the application where data is sent, each layer adds its own header to the segment. This is called data encapsulation (Figure 2). By receiving a frame for example from ethernet, the TCP/IP stack has to evaluate and remove step by step the headers of the different layers to extract the payload. A recommended source for background information about the TCP/IP software architecture is Reference [1].

**Figure 2. Data Encapsulation**

2.1 Ethernet

Today, ethernet is the most common medium to transfer data in a local area network (LAN). It belongs to the network layer in the Internet reference model. The standard IEEE 802.3 defines possible bit rates, the physical realization of bit coding, and the frame format used. Ethernet shares the bus and each network node has the same rights to access the media by the *carrier sense multiple access with collision detection* (CSMA/CD) method. If a collision is detected, the sending nodes stop transmitting and use a special back-off algorithm for retransmission. The data stream is Manchester coded and transferred using differential two-wire lines (twisted pair cable, RJ45) or coaxial cables (RG58, BNC).

Every network node has its own unique physical address. It is 48 bits long and called the *media access control* (MAC) address. The maximum length possible for an Ethernet frame is 1518 bytes. This size covers the whole frame, excluding the preamble. The preamble consists of alternating zeros and ones and is used for synchronization purposes. It is followed by the real frame. The first 48 bits are the destination and the second 48 bits are the source MAC address. After that, a 2-byte value indicating the type of the frame is sent. This type field is used to decide in the receiving stack to which upper level protocol the frame will be handed over. Afterwards a maximum of 1500 data bytes can be transferred followed by a 4-byte automatically generated cyclic redundancy check (CRC) value. Using this CRC, the ethernet ensures data integrity, but it does not ensure the delivery or in-order delivery of a packet. There are many resources on the Internet about ethernet.

2.2 Address Resolution Protocol

The address resolution protocol (ARP) is usually used in ethernet networks. Its main purpose is to determine a physical network address (e.g., Ethernet/MAC address) from a logical one (e.g., IP address) for sending packets of higher-level protocols. The network station that wants to exchange data with another peer broadcasts a packet to the LAN that is received and processed by all other peers. If a station finds out that the target's protocol address matches the one of its own TCP/IP stack, it sends back an answer frame to the sender. Now the sender knows the MAC address of its partner and can continue sending with Unicast packets. This protocol is described in detail in RFC 826 [5].

2.3 Internet Protocol

The Internet protocol (IP) is designed for use in packet-based networks such as the Internet. It provides mechanisms for transmitting datagrams from a source to a destination (addressing), and for fragmentation if necessary for transmission through small-packet networks. The demonstration board uses today's most common protocol, version four (IPv4).

The communication partners are identified by fixed-length addresses (IP addresses). But there is no guarantee for a reliable end-to-end data transmission, flow control, sequencing and other services commonly found in host-to-host protocols. If such features are needed, a higher-level protocol must be used for data transfer (the most common in Internet is the TCP). There is no assurance that the data sent along the datagram is error free, however the IP header is protected by a checksum. Each IP packet has a protocol field indicating to which upper layer protocol the carried data belongs.

Each Internet datagram is treated as a fully independent entity unrelated to any other datagram and therefore IP is connectionless. A datagram can fail to reach its destination for different reasons:

- The destination host is not connected to the network
- The datagram was damaged
- A router misdirected the datagram

Upper level protocols (for example, TCP) can compensate for these types of failures. Refer to RFC 791 [2] for a more detailed description.

2.4 Internet Control Message Protocol

The *internet control message protocol* (ICMP) provides a mechanism for reporting problems and generating diagnostic messages, e.g., when a datagram cannot reach its destination, when a gateway does not have the buffering capacity to forward a datagram, or when the gateway recommends a shorter route. Thus the datagram service can achieve a better communication reliability. The ICMP uses the basic support of IP. However, it is an integral part of the IP layer. Information about this protocol can be found in Reference [3].

The only two messages that are of interest for this application are the ECHO and the ECHO REPLY messages. They are mainly used by the operating-system command-line utility PING. It sends an ECHO message to another host which answers with an ECHO-REPLY message and also sends back the received data. The PING tool draws information about the round-trip time (RTT) and the reliability of a network.

2.5 Transmission Control Protocol

The *transmission control protocol* (TCP) is a transport-layer protocol from the TCP/IP network stack. It is a highly reliable, connection-oriented host-to-host protocol for use in a packet-switched network. It is the most established transport layer for commonly used Internet protocols (e.g. HTTP, SMTP, FTP, telnet). A simple, potentially unreliable datagram service of a lower level protocol (such as IP) is enough for TCP to provide its service. To provide this service, the following mechanisms are implemented:

- Basic data transfer: TCP splits a continuous stream of bytes in segments and sends them out as IP-frames.
- Reliability: Recovery from damaged, lost or duplicated data is achieved by assigning a sequence number to each byte and some of the special flags. The sending TCP also requires an acknowledgement from the receiving TCP. If this is not received within a timeout period, data is sent again.
- Flow control: Each time a TCP receives a frame, it tells the other TCP how many bytes it is allowed to send before further permission is needed.
- Multiplexing: The TCP introduces port numbers that allow multiplexing of IP addresses. Any combination of an IP address and a port-number is called a socket. A unique TCP connection is determined by a pair of sockets.
- Connections: Before data transfer can take place, a connection between the host and the client must be established. This is done by using a three-way handshake. During this handshake, the sequence numbers are synchronized. Afterwards the normal data transfer can begin.

A TCP session runs through different states from establishing to closing. The state changes occur as a reaction to different events. These events can be user function calls as well as receiving segments or time-controlled actions. For detailed information about the TCP state machine and how to work with it, see RFC 793 [4] and RFC 1122 [6].

2.6 Hypertext Transfer Protocol

The *hypertext transfer protocol* (HTTP) is an application level protocol. It is a generic, stateless, object oriented protocol that can be used for many tasks, such as name servers and distributed object management systems, through extension of its request methods (commands). It uses a client-server relationship and is based on a stream-oriented transport layer, such as TCP. Today, the most important use is transferring HTML documents with multimedia contents between Internet servers and clients (WWW). It works with the principle of request and response. The simplest case is that a client establishes a connection to a server and requests a content referred by a *uniform resource identifier* (URI) that specifies the path and name of the resource. Commonly, this is done by navigating with the web browser. These URIs are structured like a file path. After decoding the request, the server starts transferring the resource to the client. The requests (also called methods) are sent as simple ASCII strings with a trailing carriage return (CR) and line feed (LF) (Table 2).

Table 2. Important HTTP Methods

Method	Description
GET	A client requests a resource from a server. Afterwards, the server sends a header field and the resource to the client.
HEAD	Similar to get, but only the header-information about the resource is sent, not the resource itself.
POST	Used to transfer information from client to server (for example, pushing a button on a web page).

The response from a server contains some header lines. Each one has a CR and LF at its end. An additional CR and LF at the end of the last line of the header indicate that the data is following. In most cases, this will be an HTML page or a picture file. After transferring the content, the connection is usually closed again. HTTP protocol version 1.0 is described in RFC 1945.

3 Hardware Description

The two main components of the demonstration board are the MSP430F149 microcontroller from Texas Instruments and the CS8900A ethernet controller from Crystal™ Semiconductor Corporation.

The MSP430F149 used in the demonstration board has 60KB of flash memory and 2KB of RAM. This makes it a good choice for storing and transferring web pages. It has also six general-purpose input/output ports that can be used not only for interfacing to the LAN controller, but also to realize a user project.

The CS8900A is a low-cost ethernet LAN controller optimized for *industrial-standard-architecture* (ISA) personal computers. The features that made it very suitable for this project are its highly integrated design, which reduces the amount and cost of external components, and its very easy-to-handle bus interface. Most LAN controllers that are on the market have a PCI bus interface. The CS8900A bus interface is simple to interface with a microcontroller directly. General I/O port pins of the MSP430 are used to provide a bus interface to the LAN controller. The availability of this device in a 3-V version is another benefit for interfacing it with the MSP430.

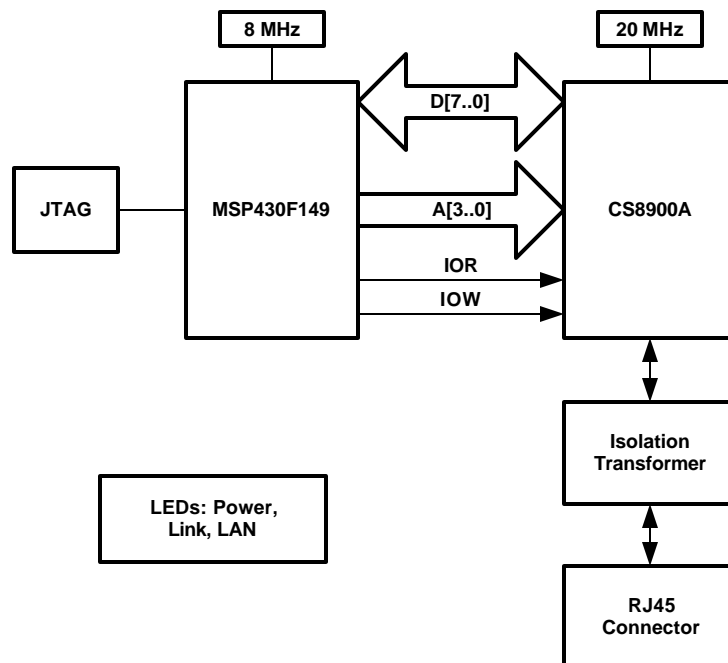

Figure 3. Hardware Block Diagram

3.1 Interfacing to the LAN Controller

The most interesting thing is the connection between the LAN controller (IC2) and the MCU (IC1). The CS8900A can operate in three different modes: I/O space, memory space, and as a DMA slave. All of these modes have their special advantages and disadvantages. For this project, the I/O space operation mode is the best choice. This is the default mode and is always enabled. The most important fact is that it is possible to use an 8-bit width data bus (see Resource [10] for a detailed description). This data bus is connected to general I/O-port 5 of the MSP430. The CS8900A in I/O mode is accessed through eight 16-bit I/O ports that are mapped into 16 registers. To access them, a 4-bit address bus width is used. There are also two control lines used, IOR and IOW. These signals are active-low and indicate whether there is a read or a write access in progress. The whole interface is implemented by using only 14 electrical signals. All unused pins of the CS8900A are driven to appropriate levels to choose the operating mode and configure the bus interface. For example, after any reset the CS8900A responds to default I/O address 0x300. The address lines that are not changed while accessing this I/O address are hardwired to 0x300.

After applying a valid I/O address to the address bus and driving one of the control lines (IOR, IOW) to low, data transfer over the data bus can take place.

3.2 Circuit Description

The analog circuitry around the CS8900A is built as further described in Resource [8]. A 20-MHz crystal is connected between the pins XTAL1 (pin 97) and XTAL2 (pin 98) of the CS8900A. Because of the built-in loading capacitance on the XTAL pins, no external capacitors are needed. The power-on reset signal is generated by the R/C combination R9/C17. The LAN controller, other than the MSP430, needs an active-high reset signal. The ethernet controller has different outputs pins to control LEDs. Pin 100 (LANLED) goes low when the CS8900A transmits or receives a frame and is connected to a red LED (D1). A yellow LED (D2) connected to pin 99 (LINKLED) is switched on if valid 10Base-T link pulses are detected. The same circuit as well as the bus interface shown can be implemented directly on a user PCB that can also contain a special analog application.

The circuitry connected to MSP430F149 contains the described connection to the LAN controller as well as a JTAG interface, a crystal oscillator and a reset circuit. The JTAG interface is designed for programming and debugging purposes. It can be used to directly connect the MSP430 flash emulation tool (FET). All required signals (for example TCK, TDI, TDO/TDI, TMS) are available at a 14-pin header (X6). An RS232 interface can be added if needed, for example to establish an SLIP or PPP Internet connection after appropriate software changes. You can use the TI device MAX3221. This part operates from a single 3.3-V supply voltage and only needs four small 0.1 μ F external capacitors. It has one serial line receiver and one serial line transmitter and also low-power features which make it very suitable for this task. To get the maximum MCU performance possible, it is sourced by an 8-MHz crystal. Two capacitors with 15 pF each are used to connect the oscillator pins to ground.

The circuit can be powered by connecting an adequate 3.3-V power supply to pin header X3. The LED D4 (green) indicates the correct supplying of the module.

All MCU pins not used, as well as the supply potentials, are connected to pin headers X3 and X4. They can be used for expansion purposes to build and attach a user application circuit.

When designing a PCB for the circuit, be certain to provide a very clean and adequate power supply to the MSP430 as well to the CS8900A by using bypass capacitors situated next to these chips and short copper traces. Also especially take care about the design of the analog part around the LAN controller (use Reference [9] as a detailed guide). For reasons of better routing ability and EMI reasons, use of a four-layered board is recommended. Figure 4 shows the prototype board used for developing the Web server software.

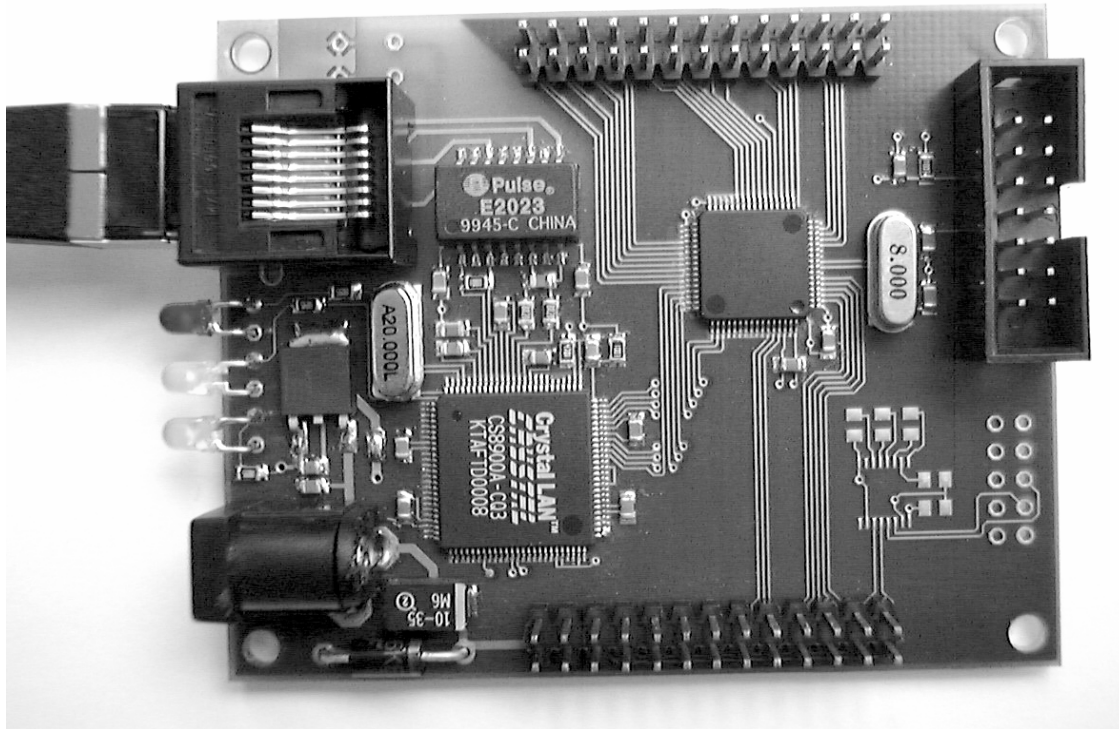

Figure 4. Prototype Board With Components Installed

Appendix A shows the schematic and Appendix B provides a list of components that are needed to build the module. For each of the discrete parts, there are several manufacturers available.

3.3 Connection to the Network

The CS8900A includes an integrated 10Base-T transceiver. It contains all the analog and digital circuitry needed for implementing the LAN interface by the use of a simple isolation transformer (IND1). Similar devices can substitute for this part, but attention must be paid to the voltage turn ratio between the primary and secondary windings. For 3.3-V operation, this must be 1:2.5 for the transmission lines and 1:1 for the receive lines. The resistor R1 is used to terminate the receive lines and the resistors R2 and R3 in series with the transmit lines are used for impedance matching. The capacitors on the LAN side of the isolation transformer (C24, C25) can be optionally populated if a shielded RJ45 connector is used. In this case, the signal GNDA must be connected to the case shield. See Reference [9] for more background information.

A standard RJ45 patch cable can be used to connect the module to either a 10-Mbps or 100-Mbps hub. A 100-Mbps hub automatically switches down its transfer speed to 10 Mbps if it detects the CS8900A running at 10 Mbps.

4 Software Description

This chapter describes the implemented TCP/IP stack, the ethernet driver, and the HTTP server. The entire software is written in C and therefore porting to other MCU systems should be quite easy. For reasons of better understanding, the code is separated into different modules. Table 3 gives an overview of these modules.

Table 3. Overview of the Software Modules

Application	<ul style="list-style-type: none"> • Transfers data via ethernet and TCP/IP • Uses the API functions of the TCP/IP module which encapsulates the whole stack and hides it from the application
TCP/IP module (tcpip.c, tcpip.h)	<ul style="list-style-type: none"> • Is a library for application development • Implements the protocols ARP, ICMP, IP and TCP • Reacts on events (frame reception, API calls by the user)
Ethernet module (cs8900.c, cs8900.h)	<ul style="list-style-type: none"> • Hardware driver for using the CS8900A LAN controller • Provides functions for configuration purposes as well as for reading and writing of registers and sending and receiving of ethernet frames
Ethernet	<ul style="list-style-type: none"> • Physical layer on which the data transfer takes place; access is via the LAN controller

NOTE: For developing a user application, it is highly recommended to use a network monitor program for examining and decoding ethernet frames (for example, Microsoft™ Netmon™).

4.1 Ethernet Module

The main task of the ethernet module cs8900.c is the encapsulation of functions for data transmission by easy-to-use C functions. The ethernet module also generates the clock scheme used for accessing the internal registers of the CS8900A.

In the header file cs8900.h, several things concerning the network interface can be configured. A very important setting is the MAC address of the network interface. This 48-bit address is defined using six symbolic constants MYMAC_1 to MYMAC_6. The user can modify this address, but must ensure that it is unique in the local network. An address of FFFF FFFF FFFF is not allowed because this is reserved as a broadcast address and therefore cannot be used as an individual one.

Table 4 gives an overview of the ethernet module procedures, and Figure 5 shows how to use them.

Table 4. Functions of the Ethernet Module

Name, Parameters	Description
void Init8900(void)	Initializes important MCU port pins, does a software reset of the LAN controller, and sets up the LAN controller MAC interface.
void Write8900(unsigned char Address, unsigned int Data)	Writes the 16-bit value Data to one of the eight possible registers of the CS8900A (Address). Data is written in little-endian byte order to the LAN controller memory.
void WriteFrame8900(unsigned int Data)	Writes the 16-bit value Data to the I/O address TX_FRAME_PORT of the CS8900A. Used to transfer a word into the transmit buffer
unsigned int Read8900(unsigned int Address)	Reads a 16-bit value from a given I/O address of the LAN controller. Byte order is little-endian.
unsigned int ReadFrame8900(void)	Reads a 16-bit value from LAN controller's RX_FRAME_PORT address. Used to transfer data to MCU memory. Byte order is little-endian.
unsigned int ReadHB1ST8900(unsigned char Address)	Reads a 16-bit value from a given address, but the byte on the upper address is read out first. This function must be used to access special registers of CS8900A. Byte order is little-endian.
unsigned int ReadFrameBE8900(void)	Reads a 16-bit value from LAN controller's RX_FRAME_PORT address. Used to transfer data to MCU memory. Byte order is big-endian. Use this function to avoid byte swapping when reading data of higher layered communication protocols.
void CopyToFrame8900(void *Source, unsigned int Size)	Copies Size bytes, starting with address Source from MCU memory to the CS8900A TX_FRAME_PORT. Used to send out a whole prepared frame.
void CopyFromFrame8900(void *Dest, unsigned int Size)	Reads out Size bytes from the LAN controller frame port and transfers it to MCU memory
void DummyReadFrame8900(unsigned int Size)	Reads and discards Size bytes from the CS8900A RX_FRAME_PORT. Used to skip a received frame. Size must be an even number.
void RequestSend(unsigned int FrameSize)	Requests FrameSize bytes in the LAN controller transmit buffer. This function must have been called before writing data to TX_FRAME_PORT.
unsigned int Rdy4Tx(void)	Checks whether previously requested buffer space in the LAN controller is available (return value is not equal to zero), and therefore the frame can be copied to the TX buffer.

At first, the ethernet controller must be configured. This is done by calling the function Init8900(). The ethernet controller is reset and the configuration sequence stored in the C-constant InitSequ[] is transferred. Every entity in this constant consists of an address and a data value. The meaning of the registers accessed and the symbols used is described in detail in the CS8900A data sheet [8]. After this preparation, data transfer can take place.

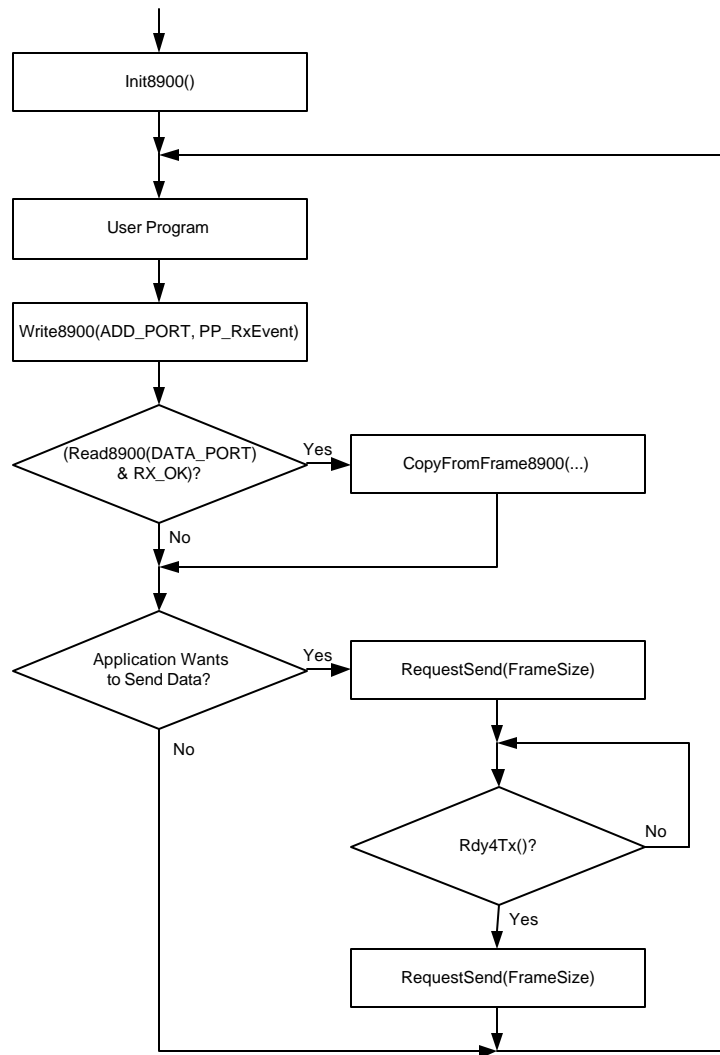

Figure 5. Using the Ethernet Module

4.2 TCP/IP Module

This software module represents the most important part of the demonstration board because the protocols for transferring data over a TCP/IP connection are implemented here. It uses functions of the ethernet module to send and receive data and provides a simple, easy-to-use API to the upper application layer.

Basically the module tcpip.c is a collection of event-handling procedures and some help functions (for example, reversing the byte order of words). In a TCP/IP stack one of the following events can occur:

- A frame is received over the LAN
- The application triggers an event (for example opens a connection, sends data...)

- A time-out is exceeded
- An error occurs (network error, connection is reset by the opponent)

The software implements the essential parts of the standards RFC 791, 792 and 793. The most important function of this stack is DoNetworkStuff(). This function must be called periodically by the user application. The event handling of the TCP is done here. Different flags are polled in both the ethernet controller and the MCU. According to the flags, this function branches to the appropriate event handler. The more often this function is called, the better the performance of the TCP is. A special set of event handlers is the user events. They are triggered by calling one of the stack functions directly by the application. These functions are described in Section 4.3.

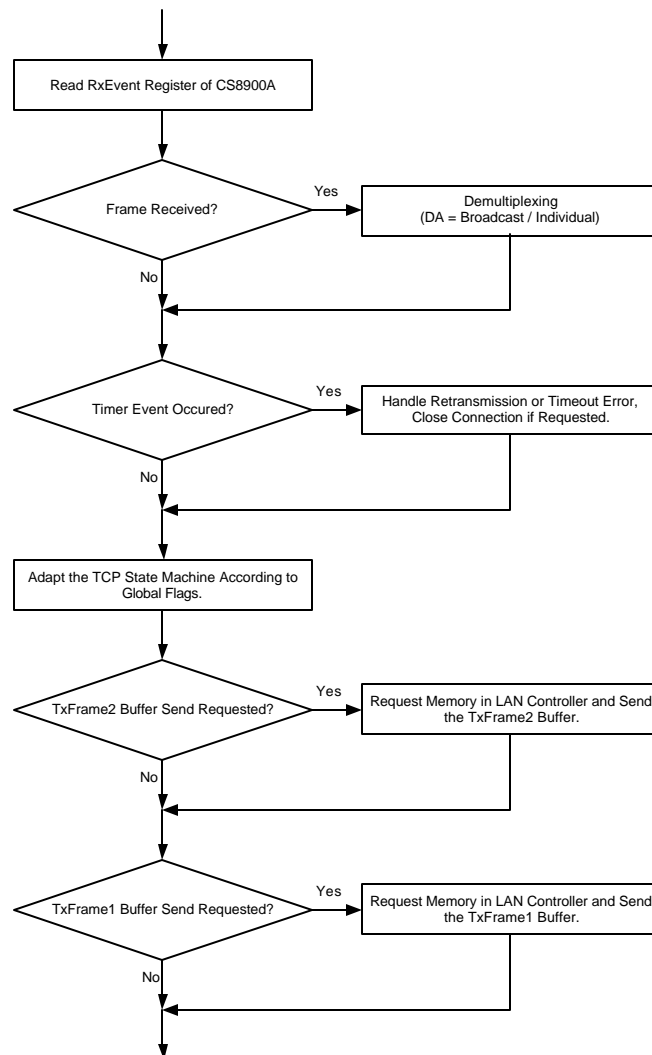

Figure 6. DoNetworkStuff() Flowchart

4.2.1 Buffer Memory

To work with incoming and outgoing frames, three memory buffers are reserved in the MCU SRAM. The size of these buffers can be adapted by changing the appropriate symbolic constants in `tcip.h`. Increasing the size of the buffers leads to a dramatic increase of the transfer speed, because the demonstration software maintains only one buffer for sending and one buffer for transmitting data over TCP/IP. This transmit buffer can be filled with new data only when the last transferred segment was acknowledged by the opponent TCP. A decrease in the transfer speed results from the round-trip times (RTT) in a wide area network (WAN).

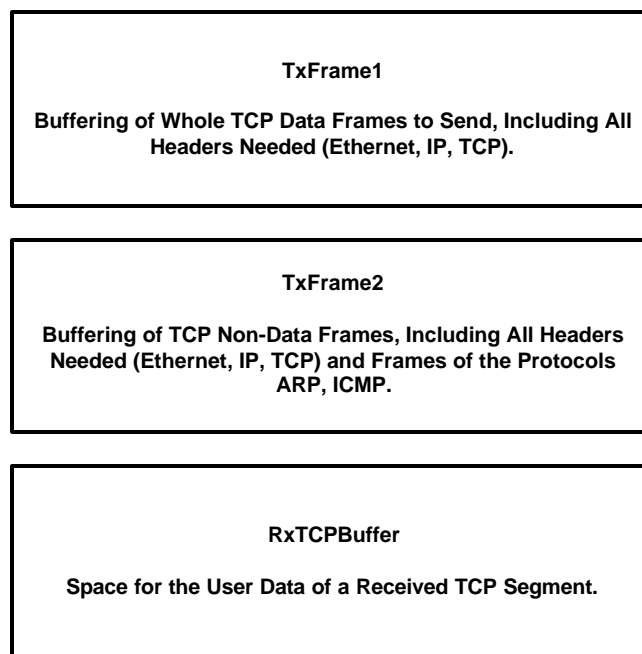

Figure 7. Buffer Concept

4.2.2 Global Variables

All information about the current state of the TCP, as well as local and remote IP addresses and port numbers, sequence numbers, timers, and counters, is stored in global variables, which are easily accessible by all of the internal stack functions.

4.2.3 Demultiplexing and Processing of Received Frames

The `DoNetworkStuff()` function checks whether a frame was received. After examination of the frame's destination to determine whether the packet is individually addressed to the module or is a broadcast frame, the function `ProcessEthIaFrame()` or `ProcessEthBroadcastFrame()` is called. Figure 8 gives an overview of which procedure is called, depending on the type of the frame received. If it was a broadcast frame and its type is an ARP request, an ARP answer frame is generated and written to the `TxFrame2` buffer.

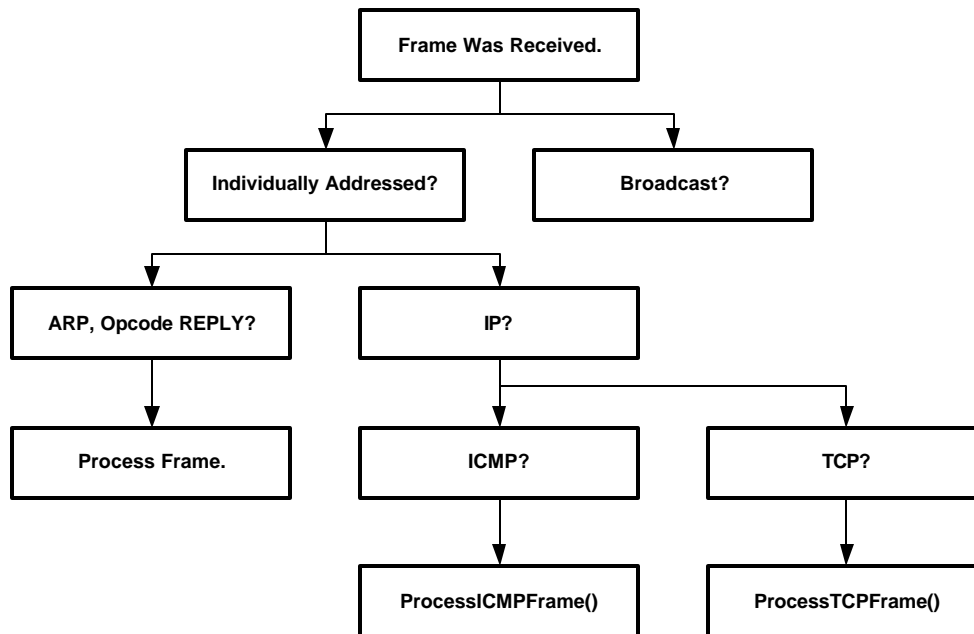

Figure 8. Demultiplexing of Received Frames

If the frame was individually addressed, it is first checked to determine if it is an ARP answer frame for a previously sent ARP request of the local TCP. In this case, the opponent's MAC address is extracted. This mechanism is used for performing an active open of a connection. For the case that the received frame type is IP and its destination address matches the one of the local TCP, a jump to the function `ProcessICMPFrame()` or `ProcessTCPFrame()` is executed, depending on the IP protocol number.

The procedure `ProcessICMPFrame()` checks to determine if the frame is an ICMP echo request and generates an ICMP echo reply. Other types of ICMP messages are ignored and discarded.

If the frame type is TCP, steps for processing incoming TCP segments recommended in RFC 793 are executed. First, the frame is checked to determine if a TCP session is active and whether the frame belongs to this session, or if a request from another TCP for establishing a connection was received (segment carries a SYN flag). Afterwards, the state of the variable `TCPStateMachine` is changed according to the flags of the segment that arrived. When data is sent along the segment and the receive buffer is empty, this data is copied to the `RxTCPBuffer` memory space. Valid arriving segments are acknowledged by sending a TCP ACK segment. The program only accepts incoming segments that correspond to the sequence number of the last segment that was acknowledged. Due to the relatively small amount of memory, no buffering can be done for segments that are delivered out of order. Preparing a non-data TCP segment is done by using the `PrepareTCPFrame()` function. A valid combination of TCP flags is passed as an argument. The whole frame (including its headers) is generated in the `TxFrame2` buffer. For example, calling `PrepareTCPFrame(TCP_CODE_ACK)` creates an acknowledgement segment.

To prevent the receive buffer from corruption while receiving data, a handshake mechanism is implemented. This mechanism uses the SOCK_DATA_AVAILABLE flag of the SocketStatus register. The TCP stack only copies data to RxTCPBuffer if the SOCK_DATA_AVAILABLE flag is clear, and only in this case is an ACK-segment sent back to the other TCP. If the RxTCPBuffer is empty and the stack has written new data to it, this is indicated to the application by setting the SOCK_DATA_AVAILABLE flag. If the receive buffer is not empty, the incoming data segment is discarded and not acknowledged. But due to the retransmission timeout of the other TCP, no data is lost, because the other TCP retransmits its data until the local TCP receive buffer is empty and can acknowledge the data. To avoid permanent retransmissions, the local application should release the receive buffer frequently by calling the API-function TCPReleaseRxBuffer() (see Section 4.3).

4.2.4 Opening a Connection

A connection can be opened in either passive or active mode by calling the proper API function TCPPassiveOpen() or TCPActiveOpen(). The TCPPassiveOpen() function places the stack in a mode in which it is attempting to detect an incoming connection. The TCPLocalPort variable must have been set to indicate which port the stack must monitor.

Before performing an active open, the IP address of the remote TCP as well as the local and remote port numbers must be set. After calling the TCPActiveOpen() function, the stack first tries to determine the MAC address of the opponent by sending an ARP request. The stack checks the destination IP to determine whether the other TCP is a member of the subnet (see symbols SUBMASK_1...4), and if so, addresses that TCP directly. If the other TCP is not a member of the subnet, the ARP request is performed for the default gateway (symbols GWIP_1...4) and data transfer occurs over the gateway as a router. For further information about subnets and gateways, see Reference [1].

After finding the MAC address to communicate with, the stack sends out a TCP segment carrying a SYN flag and the TCP option *maximum segment size* (MSS). Along with this segment, the initial sequence number required for opening a connection and also the size of the receive buffer is sent. This ensures that no arriving segment exceeds the size of the receive buffer. This frame is also prepared using the function PrepareTCPFrame().

4.2.5 Data Transfer

Once a connection is established (TCPStateMachine changes to ESTABLISHED), data transfer can begin. The actual state of the connection can be read out by using the API flag register SocketStatus (see Section 4.3). The receiving and transferring of data into the receive buffer is done by the function ProcessTCPFrame(). The count of received bytes is stored in the global variable TCPRxDataCount. New data can only be received when the receive buffer is released. Use the function TCPReleaseRxBuffer() to do this.

To send data to the other TCP, the application has to write its data into the data area of TxFrame1 buffer. For direct access to this area, the pointer TCP_TX_BUF should be used. Sending is initiated by a user call of the function TCPTransmitTxBuffer(). This function checks whether sending is allowed and then sets the flag SEND_FRAME1 in the TransmitControl register. This flag leads during execution of DoNetWorkStuff() to sending of the frame. If an acknowledge segment is received, the transmit buffer is released automatically. The application then can fill the buffer with new data and send it out.

4.2.6 Closing a Connection

A TCP connection can be closed on different events. Normally this is done either locally by calling the user function `TCPClose()` or remotely by the other TCP. During the termination of a connection, segments carrying FIN flags are exchanged. If the retransmission counter exceeds a limit or a segment with a RST (reset) flag is received, the connection is also closed. This is an error situation that is indicated by an error code in the `SocketStatus` register.

4.2.7 Using of Timers

When implementing a TCP, different tasks must be performed with controlled timing. The stack uses `Timer_A` of the MSP430, which is configured by the function `TCPLowLevelInit()`. The protocol specification for TCP (RFC 793) demands a 32-bit wide, free-running counter with a frequency of 250 kHz. It is used for getting the *initial sequence number* (ISN) needed for opening a connection. An 8-MHz crystal drives the MSP430. This clock is divided by 32, down to 250 kHz, and sources a 16-bit wide, free-running counter (TAR). An interrupt is generated each time the TAR register completes an interval (every 0.262s using an 8-MHz MCU clock). In this case, the interrupt service routine `TCPClockHandler()` increments the 16-bit number `ISNGenHigh`. This variable represents the upper word of the ISN. On each timer interrupt event, the variable `TCPTimer` is also incremented. It is used to generate the timer events needed for a TCP. For example, if the other TCP does not acknowledge a segment sent within a specific time interval, a retransmission is triggered. Also, on closing a connection, the TCP has to wait before another TCP connection can be opened.

4.2.8 Retransmission of Data

In order to avoid a breakdown of the TCP connection caused by loss of transmitted data, a time-controlled mechanism for retransmitting of data is implemented. The TCP stack writes the type of every frame sent to the `LastFrameSent` register. When the time counter exceeds the `RETRY_TIMEOUT` (symbolic constant, `tcpip.h`) limit, the frame is resent using the function `TCPHandleRetransmission()`. The maximum count of retransmissions per segment is defined in the constant `MAX_RETRYYS`. If this count is exceeded, the current TCP session is closed and an error is indicated. This mechanism is not used for sent segments that only contain an ACK flag because they are not acknowledged and therefore need no retransmission.

4.2.9 Summary

In spite of the fact that during software development many compromises were made [6], the compatibility of the stack in communicating with other TCPs is very good. No other TCP had problems establishing a connection during the software evaluation. Table 5 gives a list of several computers and operating systems where data exchange over TCP/IP is possible.

Table 5. Compatible Communication Systems

Computer System / CPU	Operating System, TCP/IP Stack
PC / Athlon™ / 1 GHz	Windows 2000
PC / Athlon / 1 GHz	Linux, kernel v 2.2.16
PC / Pentium™ / 233 MHz	Windows 98
PC / 486DX2 / 66 MHz	Windows 95
Apple™ Macintosh™ / 68030 / 50 MHz	System 7.5, Open Transport™ 1.1.2
AT Amiga™ / 68030 / 50 MHz	Kickstart 3.0, Miami 2.1
Cassiopeia™ / MIPS / 150 MHz	Windows CE 3.0

The main limitations of the protocol specifications that were made are:

- Only one TCP session possible at one time
- No reassembling of fragmented incoming IP frames
- No buffering of TCP segments which are delivered out-of-order
- No checksum checking of incoming data
- No support for IP type-of-service (TOS) and security options
- Ignoring of any TCP options

Compatibility is achieved by implementing only the important parts of the protocol specifications, but also is due to the tolerance of the other TCPs. This solution needs about 4.2KB of flash EEPROM as program memory, 100 bytes of flash EEPROM as memory for storing constants, and about 700 bytes of RAM.

The maximum transfer speed of the module cannot be defined exactly, as it largely depends on the other TCP. Normally, a TCP that fully implements the protocol specification is able to receive and buffer more than one segment at a time. Because the MSP430 has a relatively small amount of memory compared with, for example, personal computers, it can maintain only one receive and one transmit buffer. It needs to wait for an acknowledgement from the other TCP before the overwriting of buffer contents is allowed and new data can be exchanged. Because of the round-trip time (RTT) of packets sent over the Internet and the delaying of ACK segments by some TCPs, transfer speed varies significantly. During evaluation of the stack, transfer speeds between 2 and some dozens of KBps were measured. But most of the applications for an embedded web server do not require transfer speeds of several Mbps.

4.3 API

The wish to enable existing applications as well as to create new embedded applications with Internet connectivity was an important reason for this project. Without spending excessive time in understanding the details of TCP/IP, an application developer should be able to use the functionality of this stack by calling simple functions to query some flags. The API consists of a set of subroutines for sending and receiving data and a flag register that indicates the current status of stack.

Very important for the proper function of the stack is the periodic calling of the function `DoNetworkStuff()` by the application. A typical program flow chart using this TCP/IP API is shown in Figure 9.

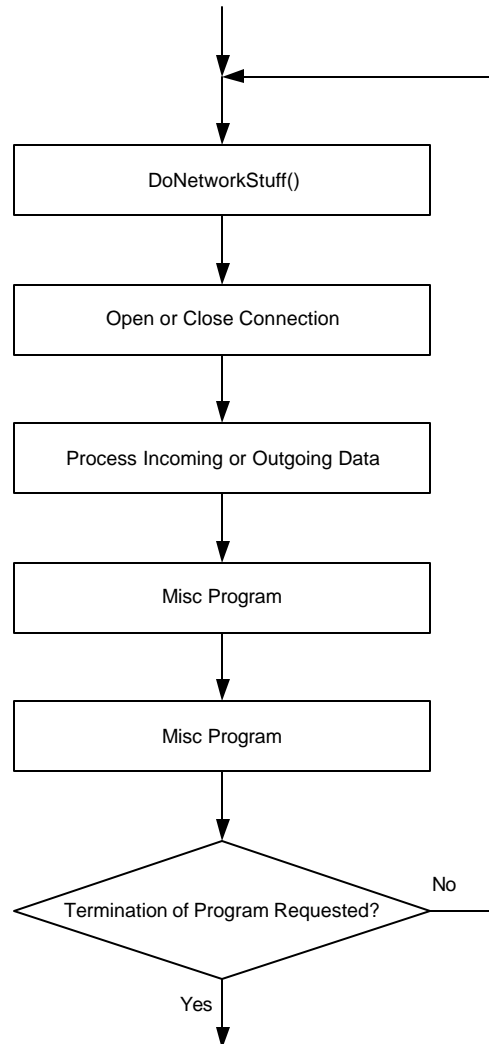

Figure 9. Using DoNetworkStuff()

The blocks containing *misc program* must not contain code which could block the periodic execution of `DoNetworkStuff()` (for example endless waiting or polling for an event). The software should use the help of timers and counters to avoid blocking. An example for this programming style is the HTTP server that is explained in Section 4.4.

4.3.1 Functions

void TCPLowLevelInit(void)

This function does a basic setup of the ethernet controller and numerous variables; it also configures ports and timer_A of MSP430. It must be called before any data transmission via TCP/IP can take place.

void TCPPassiveOpen(void)

By calling this function, the stack switches to the server mode to detect an incoming connection. The flag SOCK_ACTIVE is set indicating the stack is busy now. Before calling this function, the local TCP port must have been configured. The local IP address is specified by a constant declaration in the header file tcpip.h. The following example shows how to open a connection.

```
TCPLocalPort = 80;           // port of a HTTP-server
TCPPassiveOpen();          // listen for any incoming connection
(...)

```

If a client successfully establishes a connection to the server, the SOCK_CONNECTED flag in the register SocketStatus is set.

void TCPActiveOpen(void)

This procedure tries to establish a connection to a remote TCP server. The flag SOCK_ACTIVE is set and an ARP request to find out the MAC address of the other TCP will be sent out. If the destination IP address does not belong to the actual subnet, the IP address of the gateway is used for the ARP request instead. The IP addresses as well as the local and remote TCP port must be set up before doing an active open. After the opening of the connection, the synchronization of the TCPs, and the state change of the local TCP to ESTABLISHED, the SOCK_CONNECTED flag is set and data transfer can take place by using the appropriate API functions. If an error occurs while opening the connection (for example, destination host is unreachable), the connection is reset and an error code is stored into the SocketStatus variable accordingly.

The following example shows how to perform an active open. If the module is connected to a router and the gateway IP is configured properly, you should be able to read out the quote of the day of a real Internet server from MCU memory by using the *flash emulation tool* (FET).

```
*(unsigned char *)RemoteIP = 24;           // destination IP: 24.8.69.7
*((unsigned char *)RemoteIP + 1) = 8;
*((unsigned char *)RemoteIP + 2) = 69;
*((unsigned char *)RemoteIP + 3) = 7;

TCPLocalPort = 2025;                       // local TCP port doesn't matter (>1024)
TCPRemotePort = 17;                        // standard port: "quote of the day"

TCPActiveOpen();

while (SocketStatus & SOCK_ACTIVE)         // wait for closing the connection by the
{                                           // other TCP
    DoNetworkStuff();
}

```

void TCPClose(void)

Use this API function to close an open connection. Before disconnecting, the stack ensures that a packet that still resides in the output buffer is transmitted and acknowledged properly. After closing, the application may reconfigure IP addresses, reassign port numbers, and open a new connection.

void TCPReleaseRxBuffer(void)

After reading out the receive buffer, calling this function tells the stack that the buffer contents is not needed anymore and may be overwritten by new incoming TCP data. This function also clears the SOCK_TX_BUF_RELEASED flag used to indicate the presence of new data.

void TCPTransmitTxBuffer(void)

By using this function, an application can send data over an already opened connection. First, the application has to check if it may write data to the transmit buffer. This is done by testing the flag SOCK_TX_BUF_RELEASED of the SocketStatus register. If this flag is set, the application may write a maximum of MAX_TCP_TX_DATA_SIZE bytes to the transmit buffer, starting at address TCP_TX_BUF (points to the data section of the TxFrame1 buffer). Afterwards, the byte count must be written to TCPTxDataCount register. Finally, calling TCPTransmitTxBuffer() leads to the transmission of the data (Figure 10).

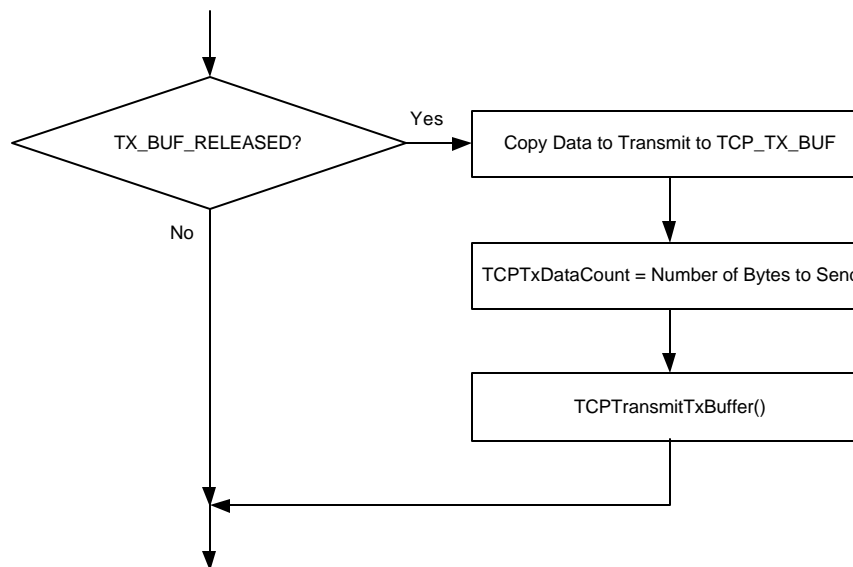

Figure 10. Transmitting of Data

4.3.2 Flags

The API status flags are stored in the global 8-bit variable SocketStatus. This register can only be read out. The bit positions of the described flags are shown in Figure 11.

Bit 7 SOCK_ ERROR	Bit 6 SOCK_ ERROR	Bit 5 SOCK_ ERROR	Bit 4 SOCK_ ERROR	Bit 3 SOCK_TX_BUF_ RELEASED	Bit 2 SOCK_DATA_ AVAILABLE	Bit 1 SOCK_ CONNECTED	Bit 0 SOCK_ ACTIVE
-------------------------	-------------------------	-------------------------	-------------------------	-----------------------------------	----------------------------------	-----------------------------	--------------------------

Figure 11. SocketStatus Register

SOCK_ACTIVE (Bit 0)

This flag is set when the TCP is busy opening a connection (previous call of an API method to open a session). While set, no further call of one of these functions is allowed. If an open fails or the connection is closed normally, the stack clears this flag again. The occurrence of a possible error is shown in the error code flags.

SOCK_CONNECTED (Bit 1)

This flag indicates that the state of the TCP state machine is established. If set, data transfer using the appropriate API function can take place. On closing or resetting a connection this flag is cleared.

SOCK_DATA_AVAILABLE (Bit 2)

This flag informs the application that a new TCP segment has just arrived and can be read out of the receive buffer. To get simple access to this buffer, the pointer TCP_RX_BUF should be used. The variable TCPRxDataCount contains the amount of data received. After reading the contents of the buffer, the application should release the buffer by calling the API function TCPReleaseRxBuffer() immediately so that the stack can fill in new data (see Figure 12). If the buffer is not released for a longer time and therefore a lot of TCP segments have to be discarded, the connection can be reset by the other TCP.

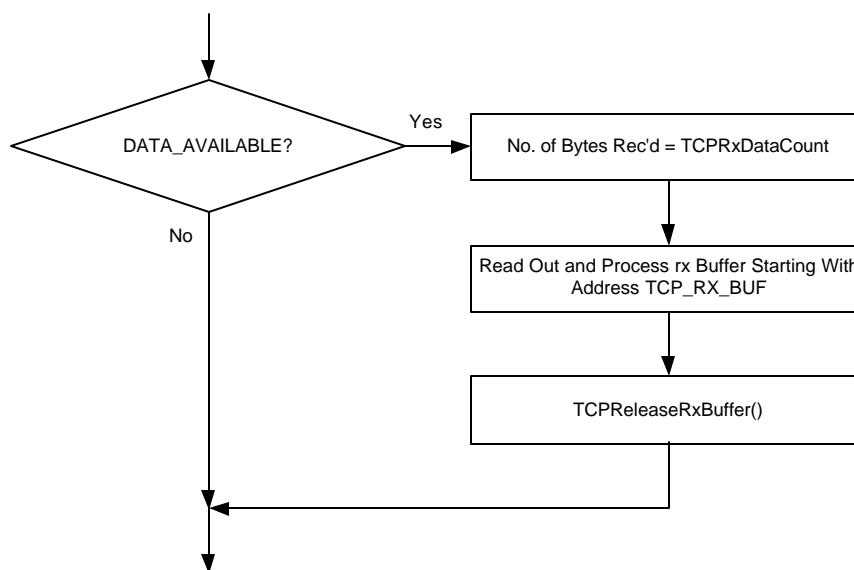

Figure 12. Data Reception

SOCK_TX_BUF_RELEASED (Bit 3)

This flag indicates whether the application can change the contents of the transmit buffer or modify the TCPTxDataCount variable. This flag is set by the stack if the previous packet sent was acknowledged properly. This realizes a kind of handshake mechanism to protect the transmit buffer from overwriting its contents. For the common way of sending data, see description of the function TCPTransmitTxBuffer().

SOCK_ERROR (Bits 4 to 7)

If an error occurs while initiating a connection or transferring data, the stack writes an error code to the upper nibble of register SocketStatus. By reading and interpreting this value, the application can find out the reason for this error. It is recommended to get the error code by isolating the upper nibble (AND-operation with SOCK_ERROR_MASK). The occurring of an error but SOCK_ERR_OK immediately closes the connection. Table 6 gives an overview about the error codes.

Table 6. Stack Error Codes

Error code	Reason
SOCK_ERR_OK	No error.
SOCK_ERR_ARP_TIMEOUT	Error during an ARP request occurred. The MAC address of the other TCP could not be found. The other host is not connected to network or is not able to answer.
SOCK_ERR_TCP_TIMEOUT	Timeout error during a TCP session occurred. Although the TCP segment was sent several times, it was not acknowledged by the other TCP. May happen on a very unreliable or interrupted connection.
SOCK_ERR_CONN_RESET	A request to open a connection or an already existing connection was reset by the other TCP. Either the other TCP cannot communicate at the given port or the application layer of the other TCP has reset the connection (for example pushing the STOP-button in an Internet browser).
SOCK_ERR_REMOTE	A fatal error of the remote TCP led to the sending of an invalid segment.
SOCK_ERR_ETHERNET	The TCP/IP stack was not able to transmit data via ethernet (the LAN controller provided no free buffer space for sending frames). This error occurs on cutting the network cable (no LINK pulses are detected by the network controller).

4.4 HTTP Server Application Example

As an example of how to use the previously described TCP/IP stack, a demonstration HTTP server was implemented. This server provides an HTML web page that is stored in MCU flash memory. The module waits for an incoming connection, transfers the web page, closes the connection and waits for another client to connect. The content of this web page is adapted dynamically to physical values. In detail, two bar graph displays are implemented for showing A/D converter values.

4.4.1 Software Description

This demonstration HTTP server is an example for the non-blocking programming style demanded in the API paragraph (Section 4.3), to keep on calling the DoNetworkStuff() function periodically. The source file name is easyweb.c and its most important function is HTTPServer(). Figure 13 shows the flowchart of this module.

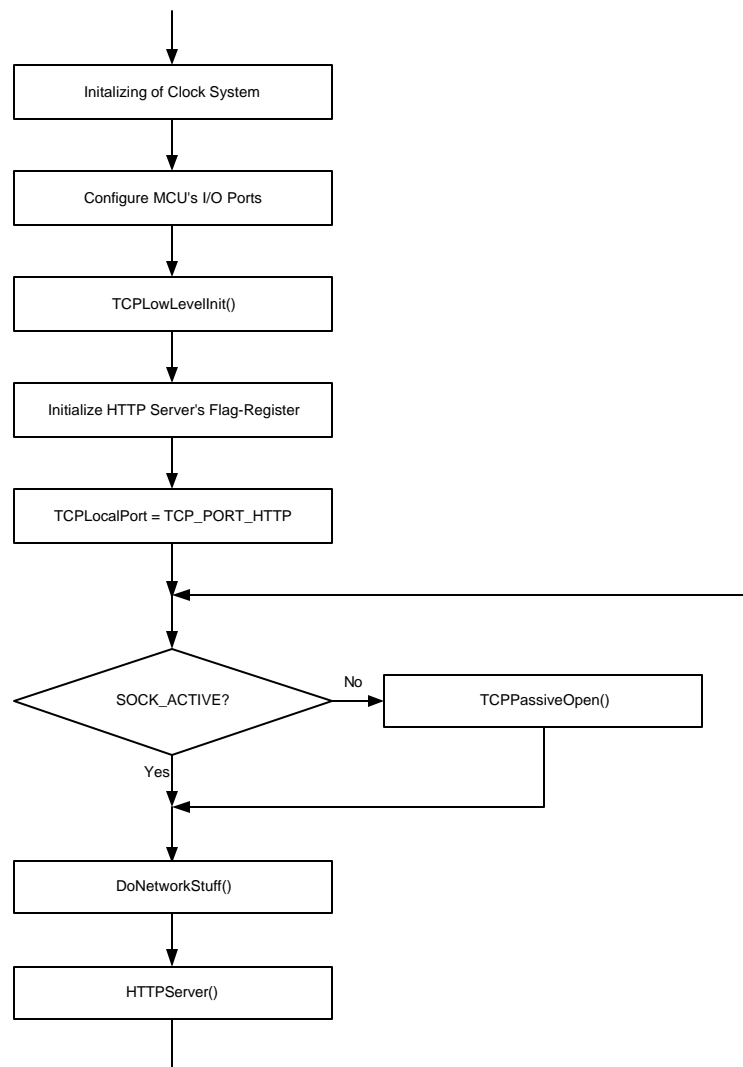

Figure 13. Web Server Main Module

After initializing some hardware and the stack itself, the local TCP port is set to 80 (default for an HTTP server). The server is now waiting for a client to be connected. During the first jump to `HTTPServer()` after connecting, the flag `HTTP_SEND_PAGE` in register `HTTPStatus` is clear. It is used to process some special code sections during this first execution of `HTTPServer()`. The web server checks for any incoming TCP data and discards it. It is assumed that the received data contains a GET request from an Internet browser. Since our server supports only one web page, this request is not evaluated. The server starts just after client connection by sending the web page stored in MCU memory. This page is stored in the C-constant `WebSide[]` in module `webside.c` and is not encoded in any special way. After checking the status of the transmit buffer, a pointer to the web side is set up and the total number of bytes to send is stored in `HTTPBytesToSend`. During the first call of `HTTPServer()`, an HTTP response header is transferred directly before the web page. It tells the client that its request was decoded successfully and lets it know what kind of resource will be transmitted (HTML). It is stored in the constant `GetResponse[]` in `easyweb.h`. After that, the web page is sent in pieces of `MAX_TCP_TX_DATA_SIZE` size. Following the successful transmission of the whole page the connection is closed by calling the API function `TCPClose()`. The connection is then reopened by the `main()` function so that the next client can request and get the web page.

How can a dynamic web page be achieved? Before sending a segment of TCP data, the function `InsertDynamicValues()` is executed. This function searches the transmit buffer for special strings. If such a string is found, it is replaced by an A/D converter value. These strings consists of four bytes: `AD` + channel number + `%`. The demonstration HTTP server replaces the string `AD7%` by the value of the A/D converter's channel seven and `ADA%` by the value of channel ten. Before inserting these values, they are scaled to a range from 0 through 100 percent. With knowledge about HTML programming, this can be used to achieve effects on the Web page.

The value for replacing the `AD7%` string is generated by the function `GetAD7Val()`. The ADC12 module of the MSP430 is configured to use an internal reference voltage of 2.5 V. Channel seven is associated with MSP430F149 port pin P6.7. The voltage of the pin is sampled and the voltage range of 0 to 2.5 V is projected into a percentage from 0 to 100. The other A/D converter function used is `GetTempVal()`. Channel ten is connected internally to a temperature reference diode. By setting the reference voltage to 1.5 V and doing a multiple conversion of eight sample points, the temperature of the MCU is measured. Using a special formula, the temperature range from 20 °C to 45 °C is converted to a percentage from 0 to 100. This formula should not be used for exact measuring; it is for demonstration purposes only.

4.4.2 Dynamic Web Page Example

The server module provides a simple web page. It uses the process of replacing special strings to be dynamic. Along with general text, two bar-graph displays showing the values of ADC12 channels 7 and 10 are displayed. For realizing such bar graph displays, HTML table commands can be used easily. Two tables having a defined width and the background color red are programmed. Within these tables, there are two more tables with the background color green. The width of the two inner tables can be referred to the width of the outer tables using a percentage. This is a good place to invoke the replacement process.

```

<html>
<head>
  <meta http-equiv="refresh" content="5">
  <title>easyWEB - dynamic Webside</title>
</head>

<body bgcolor="#3030A0" text="#FFFF00">
  <p><b><font color="#FFFFFF" size="6"><i>Hello World!</i></font></b></p>

  <p><b>This is a dynamic webside hosted by the embedded Webserver</b>
  <b>easyWEB.</b></p>
  <p><b>Hardware:</b></p>
  <ul>
    <li><b>MSP430F149, 8 MHz, 60KB Flash, 2KB SRAM</b></li>
    <li><b>CS8900A Crystal Ethernet Controller</b></li>
  </ul>

  <p><b>A/D Converter Value Port P6.7:</b></p>
  <table bgcolor="#ff0000" border="5" cellpadding="0" cellspacing="0" width="500">
  <tr>
    <td>
      <table width="AD7%" border="0" cellpadding="0" cellspacing="0">
        <tr><td bgcolor="#00ff00">&nbsp;</td></tr>
      </table>
    </td>
  </tr>
</table>

  <table border="0" width="500">
  <tr>
    <td width="20%">0V</td>
    <td width="20%">0,5V</td>
    <td width="20%">1V</td>
    <td width="20%">1,5V</td>
    <td width="20%">2V</td>
  </tr>
</table>

  <p><b>MCU Temperature:</b></p>
  <table bgcolor="#ff0000" border="5" cellpadding="0" cellspacing="0" width="500">
  <tr>
    <td>
      <table width="ADA%" border="0" cellpadding="0" cellspacing="0">
        <tr><td bgcolor="#00ff00">&nbsp;</td></tr>
      </table>
    </td>
  </tr>
</table>

  <table border="0" width="500">
  <tr>
    <td width="20%">20°C</td>
    <td width="20%">25°C</td>
    <td width="20%">30°C</td>
    <td width="20%">35°C</td>
    <td width="20%">40°C</td>
  </tr>
</table>
</body>
</html>

```

By using the REFRESH statement in the HEAD section of the page's source code, an Internet browser can be advised to reload the page after a specified timeout period. In the demonstration HTTP server, the page is reloaded each five seconds. The HTML code shown is compatible with all common Internet browsers (such as Microsoft Internet Explorer™, Netscape Navigator™).

To display the web page using an Internet browser, the user has to enter the transfer protocol (http://) together with the IP address of the module (set by default to 192.168.0.30) into the address field. See Figure 14 for a snapshot. Of course, the module must have been powered on, properly connected to LAN and the TCP/IP settings of the local machine must match to those of the module (e.g., Subnet).

Much helpful information for creating efficient HTML code can be found on the Internet.

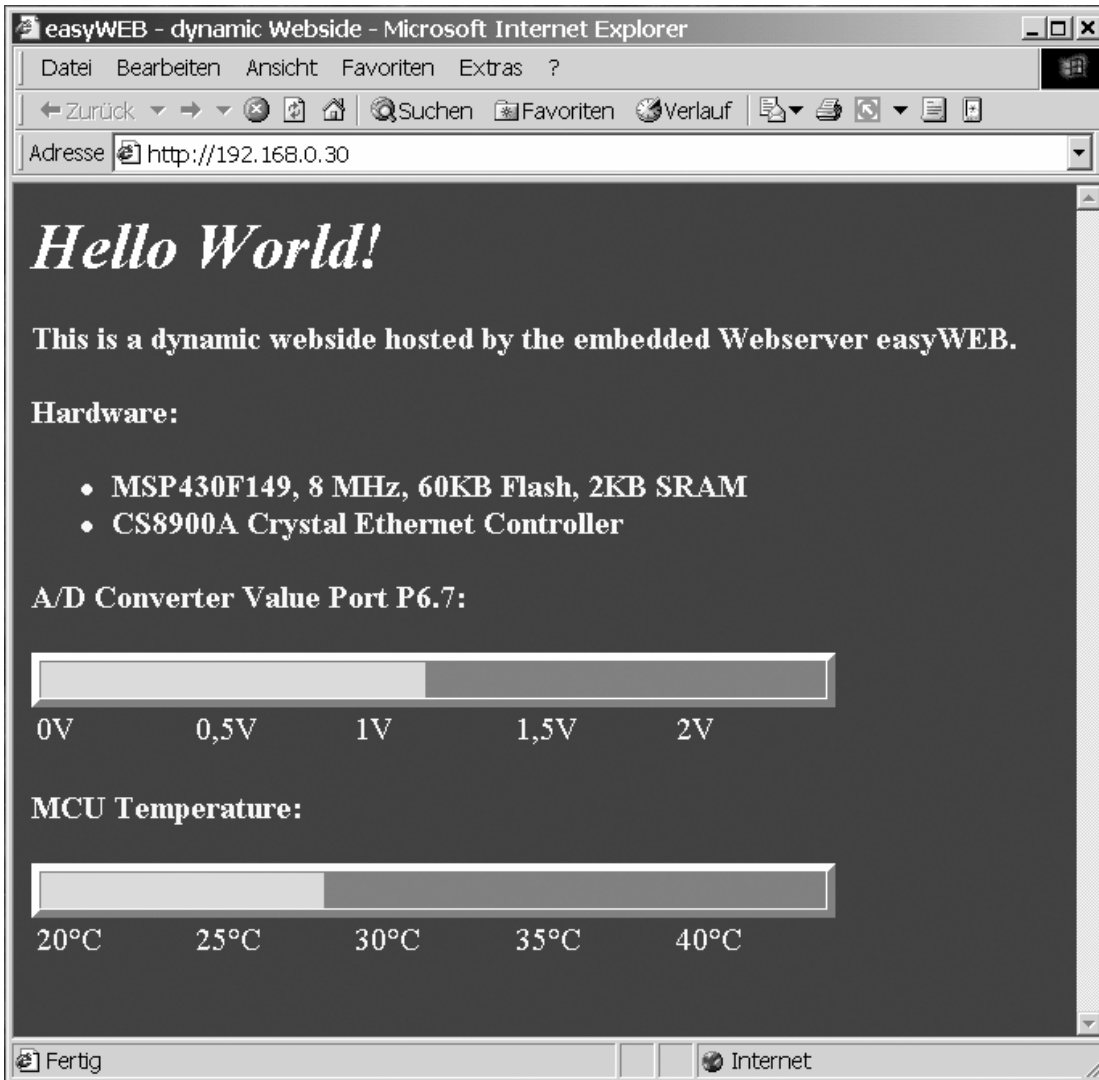

Figure 14. Internet Explorer Screen

5 References

1. *TCP/IP Running a Successful Network* by Washburn, K., Evans, J. Addison Wesley, 1996
2. *Internet Protocol (IP)* by Postel, J., RFC 791†
3. *Internet Control Message Protocol* by Postel, J., RFC 792†
4. *Transmission Control Protocol* by Postel, J., RFC 793†
5. *An Ethernet Address Resolution Protocol* by Plummer, D., RFC 826†
6. *Requirements for Internet Hosts* by Braden, R., RFC 1122†
7. *MSP430x13x, MSP430x14x Mixed Signal Microcontroller Data Sheet (SLAS272)*
8. *CS8900A Product Data Sheet*. Cirrus™ Logic, Inc., 1999‡
9. *CS8900A Ethernet Controller Technical Reference Manual (AN083)*. Cirrus Logic Inc., 2001‡
10. *Using the Crystal CS8900A in 8-Bit Mode (AN181)*. Cirrus Logic, Inc., 2000‡

† Request for Comments is a collection of papers of Internet-related topics. Available for download at <http://www.faqs.org/rfcs/index.html>

‡ Available for download from the Cirrus Logic home page at <http://www.crystal.com>

Appendix A. Application Schematic

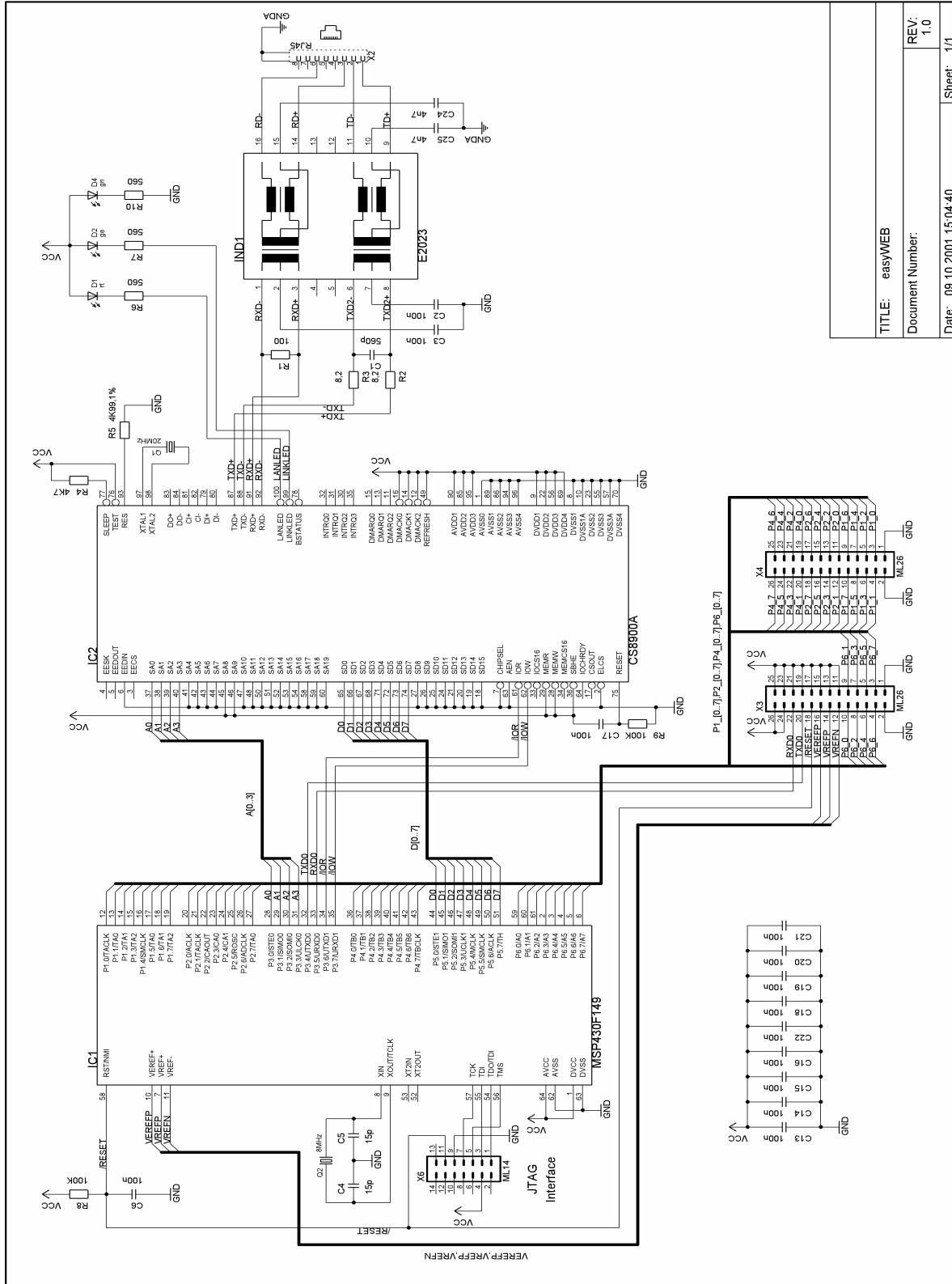

TITLE: easyWEB	REV: 1.0
Document Number:	1.0
Date: 09.10.2001 15:04:40	Sheet: 1/1

Appendix B. Parts List

Part Name	Value / Description	Package
C1	560 pF	SMT 0805
C2, C3, C6, C13, C14, C15, C16, C17, C18, C19, C20, C21, C22	0.1 μ F (100n)	SMT 0805
C4, C5	15 pF	SMT 0805
C24, C25	4700 pF / 2 kV (4n7)	
D1	LED red, 3 mm, 2 mA (rt)	
D2	LED yellow, 3 mm, 2 mA (ge)	
D4	LED green, 3 mm, 2 mA (gn)	
IC1	MSP430F149	QFP-64
IC2	ISA ethernet controller CS8900A-IQ3 (Crystal Semiconductor)	TQFP-100
IND1	Transformer E2023 (Pulse Engineering)	SO-16L
Q1	20 MHz	HC-49
Q2	8 MHz	HC-49
R1	100 Ω	SMT 0805
R2, R3	8.2 Ω	SMT 0805
R4	4.7 k Ω (4K7)	SMT 0805
R5	4.99 k Ω , 1% (4K99)	SMT 0805
R6, R7, R10	560 Ω	SMT 0805
R8, R9	100 k Ω	SMT 0805
X2	RJ45 LAN connector	
X3, X4	Header, 26-pin	ML26
X6	Header, 14-pin	ML14

IMPORTANT NOTICE

Texas Instruments Incorporated and its subsidiaries (TI) reserve the right to make corrections, modifications, enhancements, improvements, and other changes to its products and services at any time and to discontinue any product or service without notice. Customers should obtain the latest relevant information before placing orders and should verify that such information is current and complete. All products are sold subject to TI's terms and conditions of sale supplied at the time of order acknowledgment.

TI warrants performance of its hardware products to the specifications applicable at the time of sale in accordance with TI's standard warranty. Testing and other quality control techniques are used to the extent TI deems necessary to support this warranty. Except where mandated by government requirements, testing of all parameters of each product is not necessarily performed.

TI assumes no liability for applications assistance or customer product design. Customers are responsible for their products and applications using TI components. To minimize the risks associated with customer products and applications, customers should provide adequate design and operating safeguards.

TI does not warrant or represent that any license, either express or implied, is granted under any TI patent right, copyright, mask work right, or other TI intellectual property right relating to any combination, machine, or process in which TI products or services are used. Information published by TI regarding third-party products or services does not constitute a license from TI to use such products or services or a warranty or endorsement thereof. Use of such information may require a license from a third party under the patents or other intellectual property of the third party, or a license from TI under the patents or other intellectual property of TI.

Reproduction of information in TI data books or data sheets is permissible only if reproduction is without alteration and is accompanied by all associated warranties, conditions, limitations, and notices. Reproduction of this information with alteration is an unfair and deceptive business practice. TI is not responsible or liable for such altered documentation.

Resale of TI products or services with statements different from or beyond the parameters stated by TI for that product or service voids all express and any implied warranties for the associated TI product or service and is an unfair and deceptive business practice. TI is not responsible or liable for any such statements.

Following are URLs where you can obtain information on other Texas Instruments products and application solutions:

Products		Applications	
Amplifiers	amplifier.ti.com	Audio	www.ti.com/audio
Data Converters	dataconverter.ti.com	Automotive	www.ti.com/automotive
DSP	dsp.ti.com	Broadband	www.ti.com/broadband
Interface	interface.ti.com	Digital Control	www.ti.com/digitalcontrol
Logic	logic.ti.com	Military	www.ti.com/military
Power Mgmt	power.ti.com	Optical Networking	www.ti.com/opticalnetwork
Microcontrollers	microcontroller.ti.com	Security	www.ti.com/security
		Telephony	www.ti.com/telephony
		Video & Imaging	www.ti.com/video
		Wireless	www.ti.com/wireless

Mailing Address: Texas Instruments
Post Office Box 655303 Dallas, Texas 75265