



DR3000-1

- **Designed for Short-Range Wireless Data Communications**
- **Supports 115.2 kbps Encoded Data Transmissions**
- **3 V, Low Current Operation plus Sleep Mode**
- **Ready to Use OEM Module**

916.50 MHz Transceiver Module

The DR3000-1 transceiver module is ideal for short-range wireless data applications where robust operation, small size and low power consumption are required. The DR3000-1 utilizes RFM's TR1000 amplifier-sequenced hybrid (ASH) architecture to achieve this unique blend of characteristics. The receiver section of the TR1000 is sensitive and stable. A wide dynamic range log detector provides robust performance in the presence of on-channel interference or noise. Two stages of SAW filtering provide excellent receiver out-of-band rejection. The transmitter includes provisions for both on-off keyed (OOK) and amplitude-shift keyed (ASK) modulation. The transmitter employs SAW filtering to suppress output harmonics, facilitating compliance with FCC 15.249 and similar regulations. The DR3000-1 includes the TR1000 plus most configuration components in a ready-to-use PCB assembly, excellent for prototyping and intermediate volume production runs.

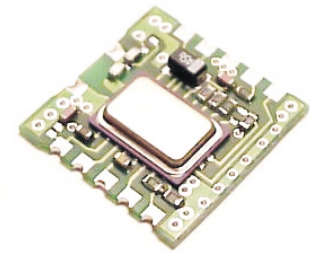

Absolute Maximum Ratings

Rating	Value	Units
Power Supply and All Input/Output Pins	-0.3 to +4.0	V
Non-Operating Case Temperature	-50 to +100	°C
Soldering Temperature (10 seconds)	230	°C

Electrical Characteristics, 115.2 kbps Amplitude-Shift Keyed

Characteristic	Sym	Notes	Minimum	Typical	Maximum	Units
Operating Frequency	f_o		916.30		916.70	MHz
Modulation Type				ASK		
Data Rate				115.2		kbps
Receiver Performance (ASK @ 115.2 kbps)						
Input Current, 3 Vdc Supply	I_R				4.8	mA
Input Signal for 10^{-4} BER, 25 °C				-85		dBm
Rejection, ± 30 MHz	R_{REJ}		55			dB
Transmitter Performance (ASK @ 115.2 kbps)						
Peak Input Current, 3 Vdc Supply	I_{TP}				12	mA
Peak Output Power	P_O			0.75		mW
Turn On/Turn Off Time	t_{ON}/t_{OFF}				1.1/1.1	μs
Sleep to Receive Switch Time (15 ms sleep, -76 dBm signal)	t_{SR}			20		μs
Sleep Mode Current	I_S				5	μA
Transmit to Receive Switch Time (15 ms transmit, -76 dBm signal)	t_{TOR}			20		μs
Receive to Transmit Switch Time	t_{RTO}				12	μs
Power Supply Voltage Range	V_{CC}		2.7		3.5	Vdc
Operating Ambient Temperature	T_A		-40		+85	°C

DR3000-1 Schematic

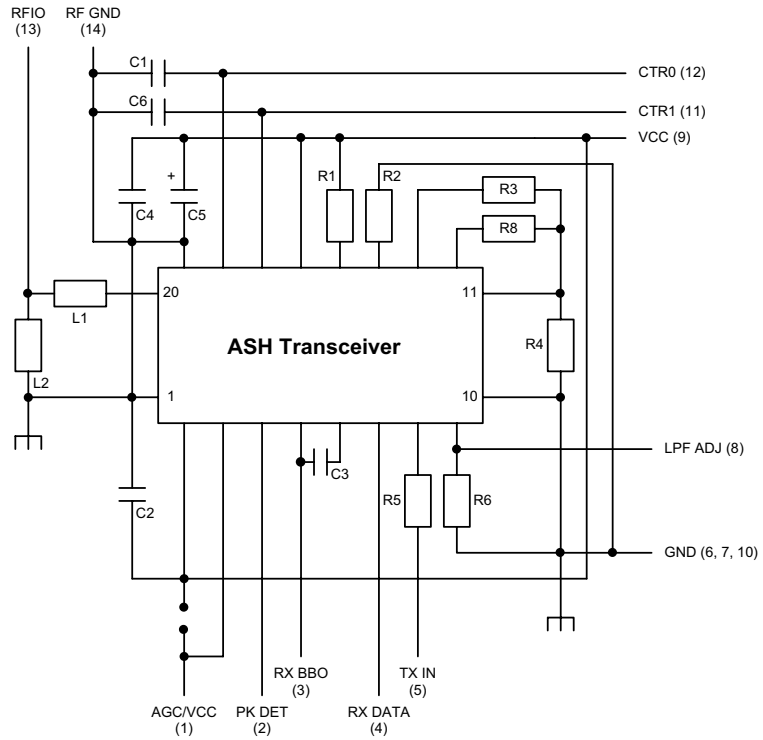

DR3000-1 Pin Out

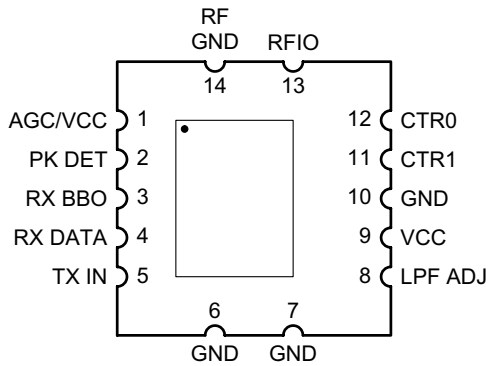

DR3000-1 Outline Drawing

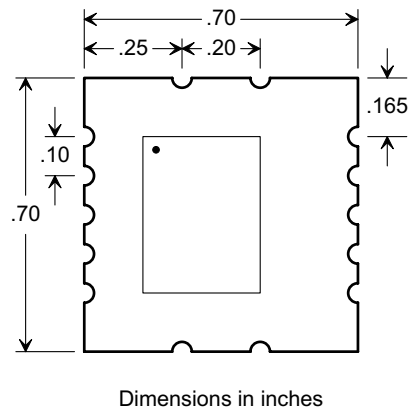

Pin Descriptions

Pin	Name	Description
1	AGC/VCC	<p>This pin is connected directly to the transceiver AGCCAP pin, which controls the AGC reset operation. To enable AGC operation (required for ASK transmission) an external capacitor is placed between this pin and ground. The capacitor sets the minimum time the AGC will hold-in once it is engaged. The hold-in time is set to avoid AGC chattering. For a given hold-in time t_{AGH}, the capacitor value C_{AGC} is:</p> $C_{AGC} = 19.1 * t_{AGH}, \text{ where } t_{AGH} \text{ is in } \mu\text{s and } C_{AGC} \text{ is in pF}$ <p>For 115.2 kbps operation, a 2200 pF $\pm 10\%$ ceramic capacitor should be used at this pin. The value of C_{AGC} given above provides a hold-in time between t_{AGH} and $2.65 * t_{AGH}$, depending on operating voltage, temperature, etc. The hold-in time is chosen to allow the AGC to ride through the longest run of zero bits that can occur in a received data stream. The AGC hold-in time can be greater than the peak detector decay time, as discussed below. However, the AGC hold-in time should not be set too long, or the receiver will be slow in returning to full sensitivity once the AGC is engaged by noise or interference. AGC operation also depends on a functioning peak detector, as discussed below. The AGC capacitor is discharged in the transceiver power-down (sleep) mode and in the transmit modes.</p>
2	PK DET	<p>This pin is connected directly to the transceiver PKDET pin. This pin controls the peak detector operation. An external capacitor between this pin and ground sets the peak detector attack and decay times, which have a fixed 1:1000 ratio. For 115.2 kbps applications, the attack time constant should be set to 0.24 μs with a 0.001 μF capacitor to ground. (This adequately matches the peak detector decay time constant of 240 μs to the time constant of the 0.0027 μF coupling capacitor C3.) A $\pm 10\%$ ceramic capacitor should be used at this pin. The peak detector is used to drive the “dB-below-peak” data slicer and the AGC release function. The AGC hold-in time can be extended beyond the peak detector decay time with the AGC capacitor, as discussed above. The peak detector capacitor is discharged in the transceiver power-down (sleep) mode and in the transmit modes. See the description of Pin 3 below for further information.</p>
3	RX BBO	<p>This pin is connected directly to the transceiver BBO pin. On the circuit board, BBO also drives the transceiver CMPIN pin through C3, a 0.0027 μF coupling capacitor ($t_{BBC} = 173 \mu\text{s}$). RX BBO can also be used to drive an external data recovery process (DSP, etc.). The nominal output impedance of this pin is 1 K. The RX BBO signal changes about 10 mV/dB, with a peak-to-peak signal level of up to 675 mV. The signal at RX BBO is riding on a 1.1 Vdc value that varies somewhat with supply voltage and temperature, so it should be coupled through a capacitor to an external load. A load impedance of 50 K to 500 K in parallel with no more than 10 pF is recommended. Note the AGC reset function is driven by the signal applied to CMPIN through C3. When the transceiver is in power-down (sleep) or in a transmit mode, the output impedance of this pin becomes very high, preserving the charge on the coupling capacitor(s). The value of C3 on the circuit board has been chosen to match typical data encoding schemes at 115.2 kbps. If C3 is modified to support different data rates and/or encoding schemes, make the value of the peak detector capacitor about 1/3 the value of C3.</p>
4	RX DATA	<p>RX DATA is connected directly to the transceiver data output pin, RXDATA. This pin will drive a 10 pF, 500 K parallel load. The peak current available from this pin increases with the receiver low-pass filter cutoff frequency. In the power-down (sleep) or transmit modes, this pin becomes high impedance. If required, a 1000 K pull-up or pull-down resistor can be used to establish a definite logic state when this pin is high impedance (do not connect the pull-up resistor to a supply voltage higher than 3.5 Vdc or the transceiver will be damaged). This pin must be buffered to successfully drive low-impedance loads.</p>
5	TX IN	<p>The TX IN pin is connected to the transceiver TXMOD pin through a 4.7 K resistor on the circuit board. Additional series resistance will often be required between the modulation source and the TX IN pin, depending on the desired output power and peak modulation voltage (3.3 K typical for a peak modulation voltage of 3 volts). Saturated output power requires about 450 μA of drive current. Peak output power P_O for a 3 Vdc supply is approximately:</p> $P_O = 4.8 * (V_{TXH} - 0.9) / (R_M + 4.7)^2, \text{ where } P_O \text{ is in mW, peak modulation voltage } V_{TXH} \text{ is in volts and external modulation resistor } R_M \text{ is in kilohms}$ <p><i>This pin must be held low in the receive and sleep modes. Please refer to section 2.9 of the ASH Transceiver Designer's Guide for additional information.</i></p>
6	GND	This is a ground pin.
7	GND	This is a ground pin.

8	LPF ADJ	<p>This pin is the receiver low-pass filter bandwidth adjust, and is connected directly to the transceiver LPFADJ pin. R6 on the circuit board (12 K) is connected between LPFADJ and ground, and sets the receiver bandwidth for typical 115.2 kbps operation. The filter bandwidth can be increased by adding an external resistor in parallel with R6. The equivalent resistor value can range from 12 K to 820 ohms, providing a filter 3 dB bandwidth f_{LPF} from 120 kHz to 1.8 MHz. The 3 dB filter bandwidth is determined by:</p> $f_{LPF} = 1445 / (12 * R_{LPF} / (12 + R_{LPF})), \text{ where } R_{LPF} \text{ is in kilohms, and } f_{LPF} \text{ is in kHz}$ <p>A $\pm 5\%$ resistor should be used to set the filter bandwidth. This will provide a 3 dB filter bandwidth between f_{LPF} and $1.3 * f_{LPF}$ with variations in supply voltage, temperature, etc. The filter provides a three-pole, 0.05 degree equiripple phase response. The peak drive current available from RXDATA increases in proportion to the filter bandwidth setting. Refer to sections 1.4.3, 2.5.1 and 2.6.1 in the <i>ASH Transceiver Designer's Guide</i> for additional information on data rate adjustments.</p>
9	VCC	This is the positive supply voltage pin for the module. The operating voltage range is 2.7 to 3.5 Vdc. It is also possible to use Pin 1 as the Vcc input. Please refer to the Pin 1 description above.
10	GND	This is a ground pin.
11	CTR1	CTR1 is connected to the CNTRL1 control pin on the transceiver. CTR1 and CTR0 select the transceiver operating modes. CTR1 and CTR0 both high place the unit in the receive mode. CTR1 and CTR0 both low place the unit in the power-down (sleep) mode. CTR1 high and CTR0 low place the unit in the ASK transmit mode. CTR1 low and CTR0 high place the unit in the OOK transmit mode (not used at 115.2 kbps). CTR1 is a high-impedance input (CMOS compatible). This pin must be held at a logic level; it cannot be left unconnected. At turn on, the voltage on this pin and CTR0 should rise with VCC until VCC reaches 2.7 Vdc (receive mode). Thereafter, any mode can be selected.
12	CTR0	CTR0 is connected to the CNTRL0 control pin on the transceiver. CTR0 is used with CTR1 to control the operating modes of the transceiver. CTR0 is a high-impedance input (CMOS compatible). This pin must be held at a logic level; it cannot be left unconnected. At turn on, the voltage on this pin and CTR1 should rise with VCC until VCC reaches 2.7 Vdc (receive mode). Thereafter, any mode can be selected.
13	RFIO	RFIO is the RF input/output pin. A matching circuit for a 50 ohm load (antenna) is implemented on the circuit board between this pin and the transceiver SAW filter transducer.
14	RF GND	This pin is the RF ground (return) to be used in conjunction with the RFIO pin. For example, when connecting the transceiver module to an external antenna, the coaxial cable ground is connected this pin and the coaxial cable center conductor is connected to RFIO.

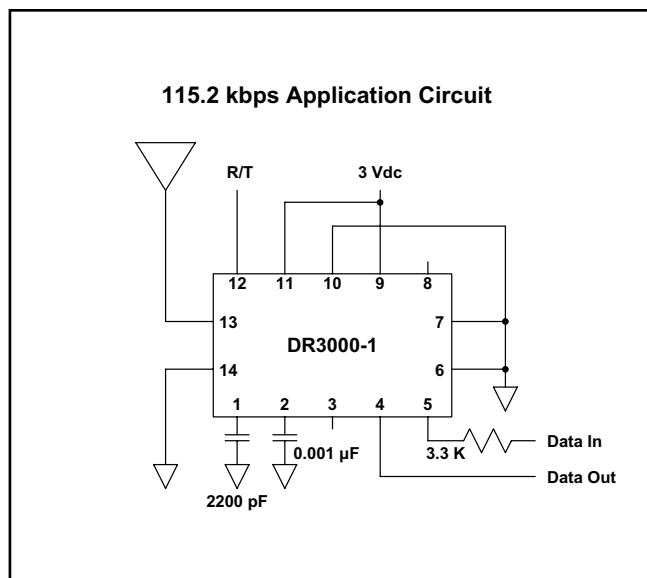

DR3000-1 Bill of Materials

Item	Reference	Description	Value	Quantity
1	IC1	TR1000 ASH Transceiver	916.5 MHz	1
2	C1, C2, C4, C6	Capacitor SMT 0603	100 pF ±10%	4
3	C3	Capacitor SMT 0603	0.0027 µF ±10%	1
4	C5	Capacitor E1A-B 0805	4.7 µF ±10%	1
5	R1	Resistor Chip 0603	1 M ±5%	1
6	R2	Resistor Chip 0603	160 K ±5%	1
7	R3, R4, R8	Resistor Chip 0603	100 K ±1%	3
8	R5	Resistor Chip 0603	4.7 K ±5%	1
9	R6	Resistor Chip 0603	12 K ±5%	1
10	L1	Inductor Chip 0603	10 nH ±5%	1
11	L2	Inductor Chip 0603	100 nH ±10%	1
12	PCB	Printed Circuit Board	400-1526-002X1	1

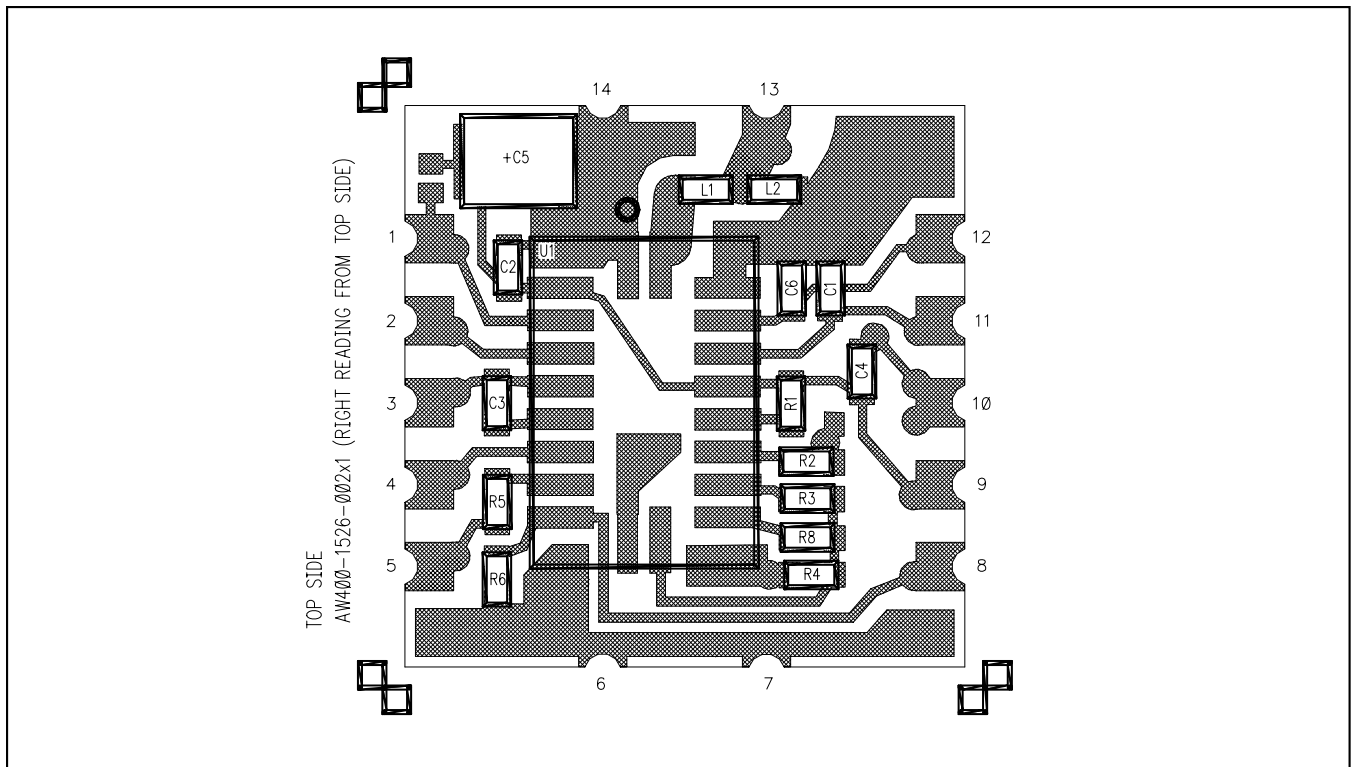

Note: Specifications subject to change without notice.

File: dr30001g.vp, 2001.09.21 rev