

# Reconfigurable Intelligent Sensors for Health Monitoring: A Case Study of Pulse Oximeter Sensor

E. Jovanov, A. Milenkovic, S. Basham, D. Clark, D. Kelley

Electrical and Computer Engineering Dept., University of Alabama in Huntsville, Huntsville, Alabama, U.S.A.

**Abstract**—Design of low-cost, miniature, lightweight, ultra low-power, intelligent sensors capable of customization and seamless integration into a body area network for health monitoring applications presents one of the most challenging tasks for system designers. To answer this challenge we propose a reconfigurable intelligent sensor platform featuring a low-power microcontroller, a low-power programmable logic device, a communication interface, and a signal conditioning circuit. The proposed solution promises a cost-effective, flexible platform that allows easy customization, run-time reconfiguration, and energy-efficient computation and communication. The development of a common platform for multiple physical sensors and a repository of both software procedures and soft Intellectual Property cores for hardware acceleration will increase reuse and alleviate costs of transition to a new generation of sensors. As a case study, we present an implementation of a reconfigurable pulse oximeter sensor.

**Keywords**—Reconfigurable Sensors, Pulse Oximeter, Intelligent Sensors, Physiological Monitoring, Programmable Logic

## I. INTRODUCTION

Wearable health monitoring systems that can be integrated into a telemedical system are a promising new information technology capable to support prevention and early detection of abnormal conditions.

Many patients can benefit from continuous monitoring as a part of a diagnostic procedure, optimal maintenance of a chronic condition or during supervised recovery from an acute event or surgical procedure. Timely warnings can be issued to the patient, and a specialized medical response service can be activated in the event of medical emergencies. Continuous monitoring with early detection likely has the potential to provide patients with an increased level of confidence, which in turn may improve quality of life. In addition, ambulatory monitoring will allow patients to engage in normal activities of daily life, rather than staying at home or close to specialized medical services.

A typical wearable health monitoring system consists of a number of physiological sensors such as movement

sensors, ECG, blood pressure, temperature & humidity, and EMG sensors. Sensor nodes exchange data and communicate with a personal server using wired or wireless communication. Wireless sensors can be implemented as tiny patches and seamlessly integrated into a body area network [1]. The system allows unobtrusive ubiquitous monitoring and can generate early warnings if received signals deviate from predefined personalized ranges. These ranges can be dynamically adapted to reflect user's state.

Future implantable sensors integrated with drug-pumps will offer the most convenient monitoring in cases of chronic diseases, where frequent sampling is necessary. A typical example of an implantable sensor under development is a blood glucose sensor for diabetic patients [2] and an implantable MEMS blood pressure sensor.

The realization of miniature and lightweight sensor nodes poses one of the most challenging tasks for designers. As sensor nodes are battery powered and have stringent requirements for size and weight, they must be extremely energy-efficient in order to avoid inconvenience due to frequent battery charges. Implantable sensors require extremely low-power operation as the battery recharging or replacement is very expensive or impossible. Communication of data over long wires or wirelessly consumes a significant energy. A common approach to lower energy consumption is to reduce required communication bandwidth by on-sensor data processing. This requires an intelligent sensor platform featuring a low-power processor or microcontroller.

Health monitoring applications usually require customization and personalization. The system should have the potential to provide personalized thresholds for a given health condition based on patient's history, environment, and relevant data such as gender, race, and age.

To address these specific requirements we introduce a concept of a reconfigurable sensor platform for medical monitoring. Reconfigurable sensor platforms offer flexibility and capability of cost-effective customization before deployment and even run-time reconfiguration if necessary. Low-power programmable logic [3] can be utilized to accelerate and reduce power consumption for a wide range of signal processing algorithms used in on-sensor processing, implement critical communication functions, and provide precise timing. While application-specific integrated circuits (ASICs), specifically designed for a target application, achieve the best performance, they lack flexibility since they cannot be changed after

deployment or the cost of that change will make it impractical. Processor-based systems guarantee flexibility since a simple program will yield a change in the system's functionality. The downside of the microprocessor-based systems is that performance may suffer and power consumption increases. Sensor platforms with programmable logic are aimed to fill the gap between hardware inflexibility and software inefficiency.

In this paper we describe a reconfigurable intelligent sensor platform capable of supporting a wide range of medical monitoring applications and dynamic reconfiguration according to the change of patient condition or operating environment. The design of the initial sensor platform relies on commercially available off-the-shelf (COTS) technology. As a case study we describe our implementation of a reconfigurable intelligent photoplethysmography sensor.

## II. METHODS

Pulse oximetry is widely used as a noninvasive, easy to use, and accurate method of estimation of peripheral blood flow, blood oxygen saturation, heart rate, and pulse amplitude [4]. However, various probes and applications require specific signal conditioning, for example ear probe vs. finger probe or children vs. adult probe.

The proposed reconfigurable sensor platform provides a common, flexible platform for a variety of physiological sensors and facilitates dynamic sensor node changes. This approach offers flexibility, customization, and seamless system integration. Moreover, possibility of code migration and hardware reconfiguration allow building of sensors that can be reconfigured after deployment or in run-time in order to adjust to new environment conditions and/or patient conditions. In addition, reconfigurable logic provides hardware acceleration of critical signal processing procedures and communication protocols, as well as precise timing for signal conditioning circuits. These decrease processing time and reduce power consumption. The reconfiguration can be triggered on-request or self-initiated. The self-initiated reconfiguration is based on parameters of a body area network or sensor platforms, such as signal to

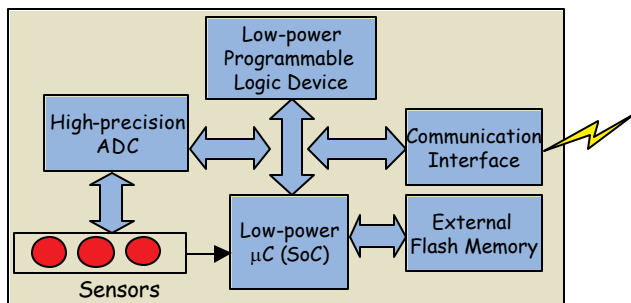

Fig. 1. Reconfigurable Medical Sensor Platform

noise ratio, battery status, precision of the measurements, and level of security.

In addition to these benefits, the development of a common platform that can be customized will increase reuse and cost-efficiency, since the common core platform can support multiple physical sensors. The envisioned repository of both software procedures and soft Intellectual Property (IP) cores for hardware acceleration will shorten design and test cycles for sensor platforms, as well as alleviate costs of transition to a new generation of sensor networks.

The proposed reconfigurable sensor platform (Figure 1) includes a combination of programmable logic and a general-purpose low-power microcontroller/processor. The general-purpose processor executes algorithms not suitable for the programmable logic, reconfigures the programmable logic during run-time, and controls the whole system. The programmable device consists of an array of computational elements known as logic blocks, a set of routing elements, and a set of input/output cells. Their functionality is determined using configuration bits [5]. The programmable logic device generates control signals and accelerates critical streaming data processing and communication tasks.

## III. RESULTS

The goal of this design project was to develop a portable, low-power, reconfigurable pulse oximeter platform. Our goal was to increase sensitivity and performance of the existing pulse oximeter devices [6], [7]), by employing a transimpedance amplifier [4]. Although we currently use standard pulse oximeter probe, the ultimate goal of our project is to develop a reconfigurable platform capable of using an integrated photodiode and transimpedance amplifier, such as OPT101 from Burr-Brown [8]. This configuration would significantly increase the performance and reduce the size of pulse oximeter sensor.

We implemented pulse oximeter in a single printed circuit board, as represented in Figure 2. The sensor consists of three functional units:

- *Signal conditioning circuit* drives red and infrared diode in a probe, amplifies, and conditions signal generated on photodiode.
- *Programmable logic device* generates control signals for the signal conditioning circuit and synchronization signals for the microcontroller.
- *Microcontroller* with integrated AD converter performs AD conversion, filtering, processing, and communication with the monitoring station.

The signal conditioning circuit amplifies a signal from photodiode caused by red and infrared diodes and ambient light [6]. As the pulsatile component of the signal does not exceed a couple of percents of the DC value, we amplify the difference between two consecutive samples to a full AD

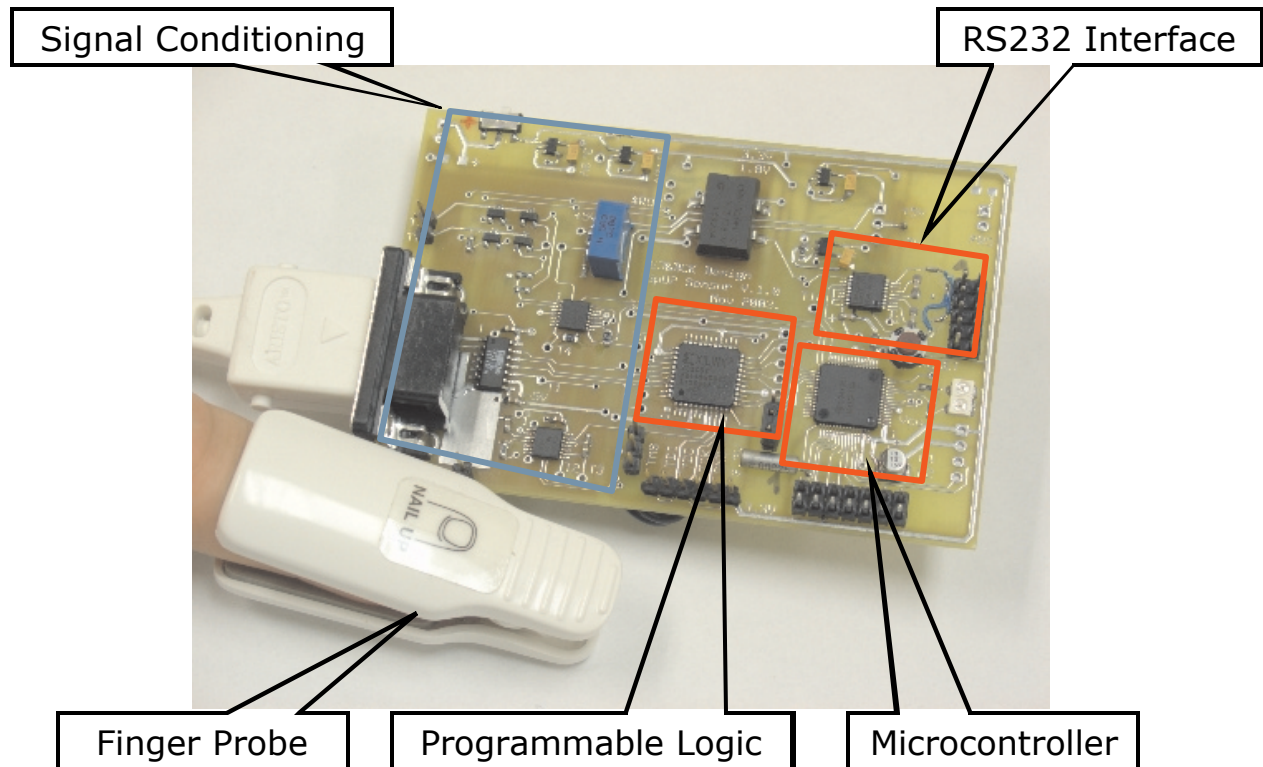

Fig. 2. Reconfigurable Pulse Oximeter Sensor

converter range. The microcontroller is responsible for the signal reconstruction.

In the current configuration we use a Texas Instruments IVC102U transimpedance amplifier to integrate the current from the photodiode in the finger probe worn by the patient. The advantage of integration is better noise immunity. However, any jitter in the timing of control signals will directly generate an undesired variation of the output values. Since the microcontroller is performing different tasks in real-time, measured jitter of control signals generated variation of the output that was not acceptable. Consequently, we had to generate a precise timing using a programmable logic device.

Control signals for the integrator are generated using Xilinx's CoolRunner-II XC2C32 – an ultra low-power CPLD (Complex Programmable Logic Device) [3]. The programmable device is controlled by the microcontroller, and it generates interrupts and status bits used for digital signal processing. Due to a variety of technology advances and an innovative design technique called RealDigital, which enables a chip core solely based on CMOS technology, the CoolRunner-II delivers high performance with the industry's lowest power - a standby current is less than 100 micro amps).

Processed results and/or raw signals are output to a PC workstation using a standard RS-232 serial link. We use a

custom application protocol for a specialized real-time monitoring program running on a PC [9]. The monitoring program can represent the results of sensor processing in low power sensor mode or display/save raw data received from sensor for debugging and algorithm development.

The core of our intelligent sensor is a low-power Texas Instruments microcontroller MPS430F149. The microcontroller features a 16-bit architecture, ultra-low power consumption (less than 1 mA in active mode and about  $\sim 1 \mu\text{A}$  in standby mode), 60KB on-chip flash memory, 2KB RAM, 8channels of 12-bit A/D converter, and a dual serial communication controller. Internal microcontroller analog channels monitor battery voltage and temperature. Therefore, the sensor is capable of reporting the battery status and temperature to the monitoring program. The microcontroller can directly control JTAG interface of the programmable device -- therefore allowing reconfiguration of the programmable logic.

#### IV. DISCUSSION

The proposed and implemented pulse oximeter sensor platform serves as a research platform for study and evaluation of typical problems relevant to the reconfigurable intelligent sensors. The main features of the realized sensor include:

- Run-time reconfiguration of the programmable logic in order to adapt to changes in the environment or patient condition and provide precise timings for signal conditioning.
- Dynamic change of program parameters and update of procedures executed on the microcontroller. This software migration can be done automatically based on the present state of the sensor or on-request. This provides support for customization and personalization of sensor settings.
- The platform is implemented as a low-power sensor device. The MSP430 features very efficient power down modes. In addition, we employ dynamic power control of the programmable logic and signal conditioning circuit.

## V. CONCLUSION

Reconfigurable intelligent sensors promise to meet major challenges in the design of cost-effective, energy-efficient, and flexible health monitoring systems capable of customization to individual users and their current state. Run-time reconfiguration can be achieved through software migration and programmable logic reconfiguration. After successful single board implementation we plan to separate the processing part of the platform from the sensor specific signal conditioning circuit, and implement system reconfiguration through a wireless communication interface. This feature will be especially important for wearable and implantable sensors.

## ACKNOWLEDGMENTS

The authors acknowledge Steve Warren of Kansas State University for help in the design of the signal conditioning circuit.

## REFERENCES

- [1] E. Jovanov, A. Lords, D. Raskovic, P. Cox, R. Adhami, F. Andrasik, "Stress Monitoring Using a Distributed Wireless Intelligent Sensor System," *IEEE Engineering in Medicine and Biology Magazine*, Vol. 22, No. 3, May/June 2003, pp. 49-55.
- [2] G. Asada, M. Dong, T.S. Lin, F. Newberg, G. Pottie, W.J. Kaiser, H.O. Marcy, "Wireless Integrated Network Sensors: Low Power Systems on a Chip," in Proceedings of the 1998 European Solid State Circuits Conference.
- [3] XILINX, CPLD Products, <http://www.xilinx.com/cpld>.
- [4] J.G. Webster (Ed.), *Design of Pulse Oximeters*, Institute of Physics Publishing, 1997.
- [5] K. Compton, S. Hauck "Reconfigurable computing: a survey of systems and software," *ACM Computing Survey*, Vol. 34, No. 2 pp. 171—210, 2002.
- [6] J.T. Love, S. Warren, G. R. Laguna, T. J. Miller, *Personal Status Monitor*, SAND97-0418, February 1997.
- [7] J. Yao, S. Warren. "Design of Plug and Play Pulse Oximeter," in Proc. 2nd Joint EMBS-BMES, Houston, Texas, October 2002, pp.1752-1753.
- [8] Texas Instruments/Burr-Brown, <http://www.ti.com>
- [9] E. Jovanov, J. Price, D. Raskovic, K. Kavi, T. Martin, R. Adhami, "Wireless Personal Area Networks in Telemedical Environment", in Proc. Third IEEE EMBS Information Technology Applications in Biomedicine – Workshop of the International Telemedical Information Society ITAB ITIS 2000, Arlington, Virginia, November 2000, pp. 22-27.