

An Environment for Runtime Power Monitoring Of Wireless Sensor Network Platforms

Aleksandar Milenkovic, Milena Milenkovic,
Emil Jovanov, Dennis Hite
Electrical and Computer Engineering Department
The University of Alabama in Huntsville
Huntsville, AL 35899 USA
{milenska | milenkkm | jovanov | hitedw}@ece.uah.edu

Dejan Raskovic
Electrical and Computer Engineering Department
University of Alaska Fairbanks
Fairbanks, AK 99775-5915
d.raskovic@uaf.edu

Key Words: Power Consumption, Wireless Sensor Networks, Real-time Monitoring, Measurements

Abstract—Wireless sensor networks emerged as a key technology for prolonged, unsupervised monitoring in a wide spectrum of applications, from biological and environmental to civil and military. The sensor networks should operate autonomously for a long period of time under stringent resource and energy constraints. Energy conservation and power-awareness have become a focus of a number of research efforts, as sensor network nodes must operate on batteries or use energy extracted from the environment, such as solar energy or vibrations. Runtime power measurements and characterization of real existing systems are crucial for studies that target power optimizations, including techniques for dynamic adaptation based on the current energy status. This paper introduces an environment for unobtrusive real-time power monitoring that could be used for a number of wireless sensor platforms. We describe our methodology for calibration and validation of the environment and give empirical data for the Telos wireless sensor platform when it runs a subset of representative applications.

I. INTRODUCTION

Recent technology advances in sensors, microprocessors, and wireless communications have enabled design and proliferation of ad-hoc wireless sensor networks. These networks consist of a large number of inexpensive and miniature sensors that can monitor and control environments without human intervention for a long period of time. Current research efforts aim at developing of new sensing devices, architectures for sensor platforms [1] [2], wireless communication protocols [3] [4] [5], as well as system support for design and evaluation of sensor networks [6] [7].

Energy consumption is a first class design constraint in wireless sensor networks as they are typically battery operated. To extend each node's lifetime it is necessary to reduce power dissipation as much as possible; dissipation below 100 microwatts will enable operation on energy scavenged from the environment. Various design trade-offs between communication and on-sensor computation,

collaborative protocols, and hierarchical network organization can yield significant energy savings. Once the sensor network is deployed dynamic power management techniques can be employed in order to maximize battery lifetime [8].

Wireless sensor network designers need a toolbox that will allow them to perform fast and accurate assessment of various design alternatives and trade-offs between design parameters, such as performance, total power consumption, reliability, and system lifetime. One approach to this challenge is to rely on full system simulators; however, they are not readily available, suffer from inaccuracies, and require long simulation time. In addition, designers often need the ability to measure live, running systems, and correlate measured data with overall hardware and software behavior. Power measurements in lab setup often fail to capture the pattern of power load of sensor nodes after they are deployed in real environments.

In this paper we present an inexpensive environment for unobtrusive power measurements for wireless sensor network platforms and describe its calibration and validation. The setup utilizes a clamp-on current probe rather than a commonly used shunt resistor. We have developed several illustrative TinyOS applications and collected their power traces for the Telos platform [9] that features a recently introduced IEEE 802.15.4-compliant wireless transceiver [10] and an ultra-low power microcontroller MSP430 [11]. In addition to power optimization and application tuning, the collected power traces can be used as an input for mathematical models designed for fast approximations of overall power consumption, or for initialization and calibration of more precise power simulators for wireless sensor networks, such as PowerTOSSIM [6].

The rest of the paper is organized as follows. Section 2 describes common techniques used for power measurements. Section 3 presents our setup for unobtrusive power measurements and its calibration. Section 4 presents power traces for several characteristic TinyOS applications running on a Telos A wireless sensor platform. Section 5 describes future work and concludes the paper.

II. POWER MEASUREMENTS

Power consumption of a system under test is commonly determined in two ways (Fig. 1): using a clamp-on current probe or a shunt resistor [12]. With the first approach we sample the power supply and the output voltage from the current probe, which is typically a linear function of current through the clamp (1). With the second approach we sample the power supply and the voltage at the shunt resistor that is a direct function of the current; the total power consumption of the system under test can be calculated as in (2). While measurements with current probes are unobtrusive, shunt resistors interfere with operation of the system under test and are unsuitable when there are large variations of current.

$$P_{SUT} = V_{SUT} \cdot I = V_{SUPPLY} \cdot I, \quad I = f(V_{CPROBE}) \quad (1)$$

$$P_{SUT} = V_{SUT} \cdot I = (V_{SUPPLY} - V_{SHUNT}) \cdot \frac{V_{SHUNT}}{R_{SHUNT}} \quad (2)$$

It should be noted that cycle-accurate energy characterization can be done using a recently proposed measurement system based on charge transfer [13]. However, this approach is rather expensive in time and cost, yet this level of precision is not necessary for determining power profiles.

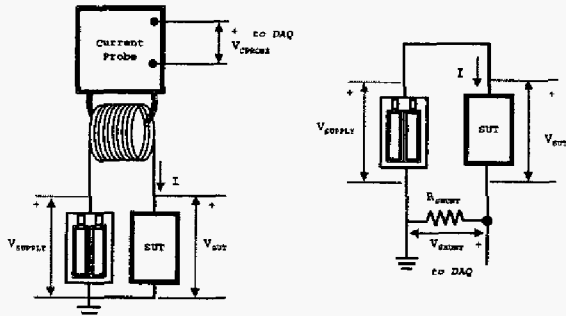

Fig. 1. Power measurements with current probe (left) and shunt resistor (right); SUT – System Under Test.

III. SETUP FOR POWER MEASUREMENTS

The block diagram of our environment for run-time power measurements is shown in Fig. 2. The environment consists of the following subblocks:

- The system under test – a wireless sensor platform and an energy source;
- The data acquisition subblock – a current probe for unobtrusive current measurements, a signal conditioning circuit, and a data acquisition card;
- The validation and calibration subblock – a digital multimeter;
- The logger laptop computer for data logging, processing, and inspection.

Fig. 3 shows a photo of our power measurement setup. To measure current through the power line we use an ExTech

380946 current probe. The output voltage from the current probe is connected to an Agilent 34401A digital multimeter (DMM), and a National Instrument DAQCard-AI-16XE-50 data acquisition card. Both voltage from the battery and voltage from the current probe are sampled with up to 200K samples per second. A LabView application running on the logger laptop collects voltage data from the current clamp and voltage data from the battery. The data are stored and later processed in MATLAB.

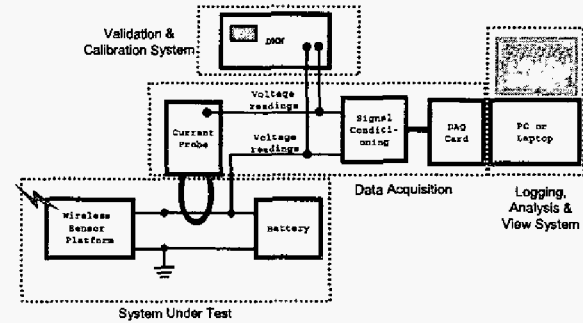

Fig. 2 Block diagram of the environment for run-time power monitoring for wireless sensor platforms. Description: DMM – Digital Multimeter, DAQ – Data Acquisition Card.

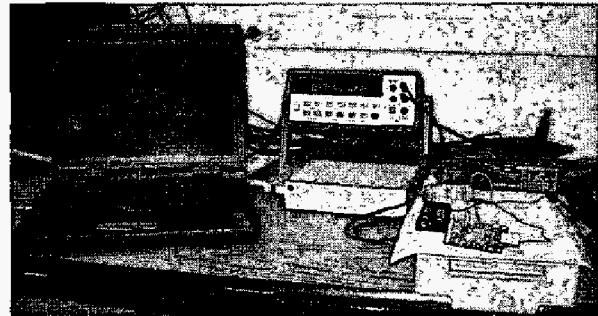

Fig. 3 Setup for power measurements for wireless sensor platforms. Description: Telos platform, 2xAA batteries, Current clamp ExTech 380946, Agilent 34401A Digital Multimeter, Shielded Connector Block SCB-68, National Instruments DAQCard-AI-16XE-50, LabView running on a laptop computer.

The current probe, which is clamped directly around the power supply line, produces an output voltage that is proportional to the current in the line. The current probe sensitivity is 1mV output voltage for 1mA of current. To increase the sensitivity of the current probe we made a solenoid with 10 rings of the power supply line. We selected this solenoid since the expected current is in range 0-40 mA, and the smallest probe range is 0-400 mA. The setup is calibrated using a simple circuit with the power supply and a resistor. We measured both the current I_{TEST} and the power supply V_{TEST} for a range of resistors with resistances from 70 Ω to 3 K Ω using the digital multimeter. The results are shown in Fig. 4. Though we confirmed expected linear dependency, we found that it could be better approximated

with a second order polynomial, since the mean squared deviation with the polynomial is 3.26 times less than with the linear function. Current in milliamps is calculated from voltage in volts as shown in (3).

$$I = -20 \cdot V_{CPROBE}^2 + 99.1 \cdot V_{CPROBE} + 0.1576 \quad (3)$$

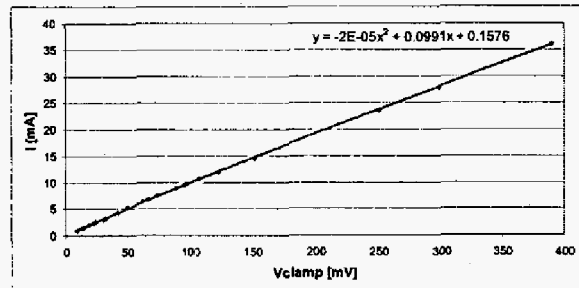

Fig. 4. Current probe calibration.

All current probes are susceptible to noise. The output voltage of the selected current probe with open solenoid ends is in the range of -7.41 to 7.44 mV, with the mean value of 0.36 mV and standard deviation of 1.55 mV (Fig. 5), with the sampling frequency of 100 Ksamples/sec. Spectral analysis of the noise shows distinct frequency components close to $5+10x$ KHz, $x = 0, 1, 2, 3, 4$ (Fig. 6). We verified whether these components come from aliasing high frequencies, by applying a low-pass RC filter with 50 KHz cut-off frequency on the current probe output. The spectrum of noise was not changed with this filter. This noise can be reduced with a low-pass RC filter, but at the price of flattening the real signal.

All power traces are collected with a sampling frequency of 200 Ksamples/sec and they are compared to the corresponding traces collected using a shunt resistor. In general, the shunt resistor traces are less susceptible to noise, but the trace collection is not unobtrusive.

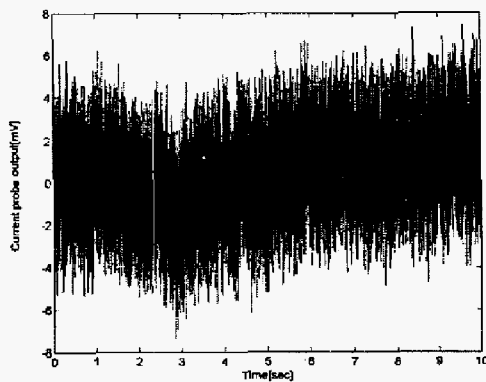

Fig. 5. Output voltage from the current probe with open solenoid ends. Sampling rate is 100 KSamples/s.

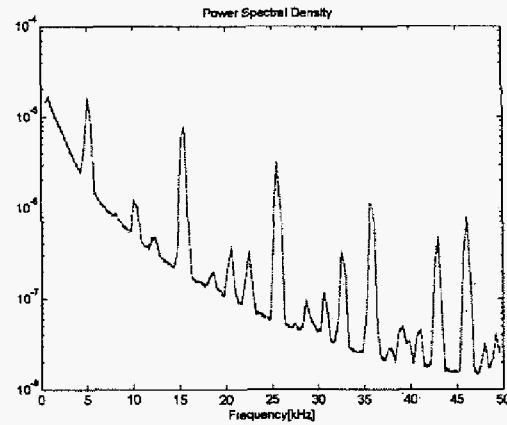

Fig. 6. Power spectral density of noise.

IV. RESULTS

Power measurements are performed using Telos, a recently introduced wireless sensor platform designed for low-power operation, ease of use, and hardware and software robustness [9]. Telos is powered by two AA batteries and features a Chipcon 2420 radio in the 2.4 GHz band [10]; an 8 MHz Texas Instruments MSP430 microcontroller [11]; an integrated onboard antenna with 50 m range indoors / 125 m range outdoors; a USB port for programming and communication; an external flash memory; and integrated humidity, temperature, and light sensors. The MSP430 microcontroller is based around a 16 -bit RISC core integrated with RAM and flash memories, analog and digital peripherals and flexible clock subsystem. It supports several low-power operating modes and consumes as low as $1 \mu\text{A}$ in a standby mode; it also has very fast wake up time of no more than $6 \mu\text{s}$. Telos Revision A features a MS430F149 microcontroller with 2 KB RAM and 60 KB flash memory; Telos Revision B features a MSP430F1611 with 10 KB of RAM and 48 KB of flash memory. The CC2240 wireless transceiver is IEEE $802.15.4$ compliant; it has programmable output power, maximum data rate of 250 Kbps, and hardware support for error correction and encryption. The CC2240 is controlled by the MSP430 microcontroller through the SPI port and a series of digital I/O lines with interrupt capabilities.

To demonstrate characteristic behaviors of wireless sensor platforms we have collected power traces for several TinyOS applications [14]. First, we measured *CntToLedsAndRfm*, which increments an internal counter variable with a 4 Hz frequency. On each counter tick, the least significant 3 bits of the counter are displayed on the Telos LEDs and the radio transmits the entire 16 -bit counter value. Fig. 7 shows a 10 -second power trace for *CntToLedsAndRfm*. The power trace clearly indicates repeating 2 -second sequences, each cycling through the counter sequence $0 - 7$ and radio transmission.

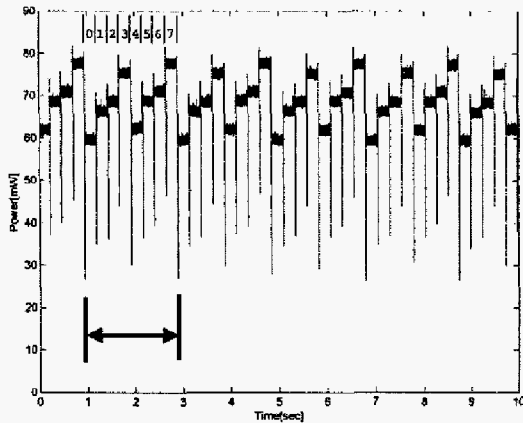

Fig. 7. Power traces the CntToLedsAndRfm application under TinyOS running on a Telos A platform.

To illustrate low-power operating modes and breakdown of power consumption for the radio and the MSP430 we have developed a TinyOS application named *Testera*. In this application a Timer event is triggered every 125 ms. In the Timer interrupt routine a 16-bit counter variable *Cnt* is incremented by modulo 1024. The current value of *Cnt* is placed in a buffer that keeps 10 most recent counter values. When the buffer is full a message is prepared (26 byte payload) and sent over the radio. A power trace of the Telos A platform when running *Testera* for 5 s is shown in Fig. 8. In this trace we can clearly identify small peaks when the MSP430 is waken up to update the *Cnt* counter; a magnified power trace of 5 ms is shown in the left box in Fig. 8. Every 10th counter update involves an RF message transmission; a magnified power trace of 10 ms is shown in the right box (Fig. 8). The total power consumption is nearly constant around 65 mW and is predominantly determined by power consumed by the radio. The C2420 radio draws 20 mA in the receive mode and 17.4 mA in the transmit mode. The power trace allows us to clearly identify different phases of the application execution, such as the count up, communication between the MSP430 and the CC2420 over the SPI port, and the very message transmission.

Application *TesteraRadioOnOff* is built upon *Testera* and utilizes *Split Radio Control* interface. This interface allows programmable control over the radio. The radio is turned on only when a radio packet is ready to be sent. When the message buffer is full, instead of an immediate sending of the message, a request for *RadioOn* is initiated. When we receive confirmation that the radio is on and ready to receive a new message, the message is sent. Upon receiving confirmation that the message has been sent, the radio is turned off. A power trace for this application is shown in Fig. 9. The total power consumption averages around 5 mW with peaks around 9 mW in timer interrupt routines. The left block in Fig. 9 shows a magnified power trace of 5 ms for the count

up event. The right block in Fig. 9 shows a magnified power trace of 40 ms during packet radio transmission. The whole event when the buffer is full now encompasses several steps that precede radio transmission. It takes approximately 6 ms to start the radio, then the MSP430 sends the message over the SPI, and finally the message is transmitted over the radio.

All measurements are repeated with the setup with shunt resistors. We evaluated several configurations with $R_S=0.5 \Omega$ and $R_S=4.8 \Omega$. The traces collected on the shunt resistors exhibit the same trends as the traces collected with the current probe. However, the actual values of samples are lower due to presence of the shunt resistor. Fig. 10 shows a power trace for the *Testera* application taken with $R_S=4.8 \Omega$.

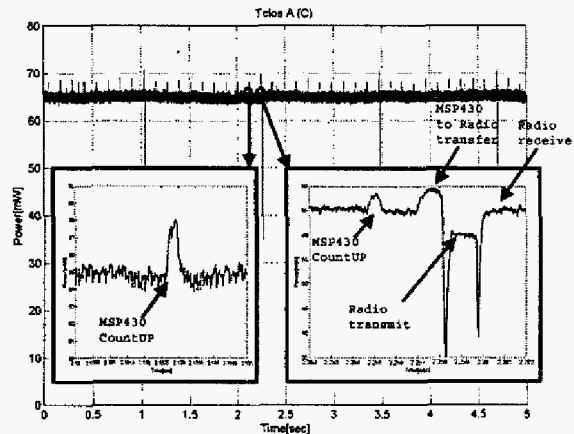

Fig. 8. Power traces for the *Testera* TinyOS application running on Telos A.

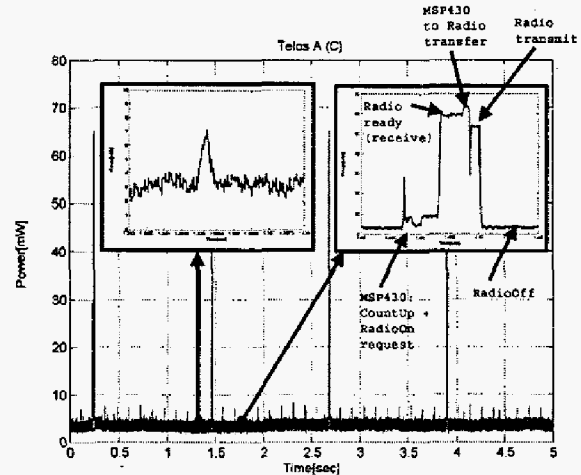

Fig. 9. Power traces for the *TesteraRadioOnOff* TinyOS application running on Telos A.

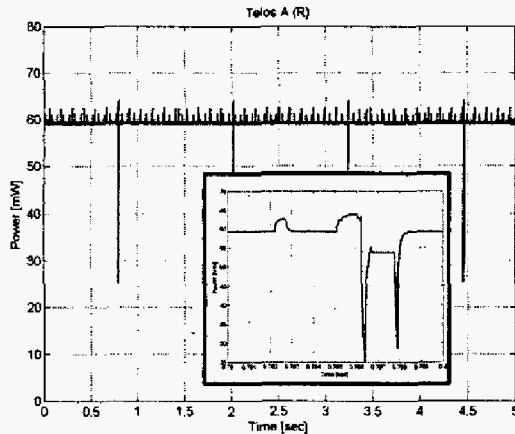

Fig. 10. Power traces for the Testera TinyOS application running on Telos A measured by the shunt resistor.

V. CONCLUSIONS

The primary contributions of this paper are as follows:

- We describe an environment for collection and processing of runtime power traces for wireless sensor platforms.
- We describe verification and calibration of the environment. Once verified and calibrated, the setup can be easily used for live measurements of deployed wireless sensor networks, to help fine-tuning and power optimizations.
- We present runtime total power measurements for the Telos platform and characterize power consumption for several typical operating modes.

This setup can be used for various research efforts targeting energy-efficient sensor networks. In particular, we plan to use it for after-deployment tracing in order to capture sensors behavior in real environments, where temperature, supply voltage, and type of responses are likely to vary significantly in time. The existing set of applications can also be extended with new microbenchmarks that will capture power traces when multiple physical signals are sensed (AD converter), stored locally in the external flash memory, and later transmitted. Various design trade-offs can be evaluated, for example, effects of data compression and encryption.

VI. ACKNOWLEDGMENTS

This work is being supported in part by a National Science Foundation grant IIS-0434156 and the University of Alabama in Huntsville.

VII. REFERENCES

- [1] J. Hill, R. Szewczyk, A. Woo, D. Culler, S. Hollar, and K. Pister, "System Architecture Directions for Networked Sensors," in *Proceedings of the 9th ASPLOS*, Cambridge, MA, 2000, pp. 93 -- 104.
- [2] J. Hill and D. Culler, "MICA: A Wireless Platform for Deeply Embedded Networks," *IEEE Micro*, vol. 22, November 2002, pp. 12 -- 24.
- [3] J. M. Rabaey, M. J. Ammer, J. L. d. S. Jr., D. Patel, and S. Roundy, "PicoRadio Supports Ad Hoc Ultra-Low Power Wireless Networking," *IEEE Computer*, vol. 33, July 2000, pp. 42 - 48.
- [4] S. Roundy, B. Otis, Y.-H. Chee, J. Rabaey, and P. Wright, "A 1.9GHz RF Transmit Beacon Using Environmentally Scavenged Energy," in *Digest IEEE Int. Symposium on Low Power Elec. and Devices*, Seoul, Korea, 2003, pp. -.
- [5] --, "Zigbee Alliance", <<http://www.zigbee.org/>> (2004).
- [6] V. Shnayder, M. Hempstead, B.-r. Chen, G. W. Allen, and M. Welsh, "Simulating the Power Consumption of Large-Scale Sensor Network Application," in *Proceedings of the Second ACM Conference on Embedded Networked Sensor Systems (SenSys'04)*, Baltimore, MD, USA, 2004, pp. 188 -- 200.
- [7] P. Levis, N. Lee, M. Welsh, and D. Culler, "TOSSIM: Accurate and Scalable Simulation of Entire TinyOS Applications," in *First ACM Conference on Embedded Networked Sensor Systems (SenSys 2003)*, Los Angeles, California, USA, 2003, pp. 126 - 137.
- [8] A. Sinha and A. Chandrakasan, "Dynamic Power Management in Wireless Sensor Networks," *IEEE Design & Test of Computers*, vol. 18, March 2001, pp. 62 -- 74.
- [9] J. Polastre, R. Szewczyk, and D. Culler, "Telos: Enabling Ultra-low Power Wireless Research", <<http://www.moteiv.com>>
- [10] --, "Chipcon RF Tranceivers", <www.chipcon.com>
- [11] --, "MSP430 MCUs", <www.ti.com/msp430> (January 2004).
- [12] D. Raskovic, "Energy-efficient Hierarchical Processing in the Network of Wireless Intelligent Sensors (WISE)," Ph.D. Thesis, ECE Dept., University of Alabama in Huntsville, 2004.
- [13] N. Chang, K. Kim, and H. G. Lee, "Cycle-accurate Energy Measurement and Characterization With a Case Study of the ARM7TDMI," *IEEE Transactions on Very Large Scale Integration (VLSI) Systems*, vol. 10, April 2002, pp. 146 -- 154.
- [14] --, "TinyOS", <<http://www.tinyos.net/>>