

CPE 323 Introduction to Embedded Computer Systems: ADC12 and DAC12

**Instructor: Dr Aleksandar Milenkovic
Lecture Notes**



Outline

MSP430: System Architecture

- ADC12 Module
- DAC12 Module



ADC12 Introduction

- ADC12 module supports fast, 12-bit analog-to-digital conversions
 - 12-bit SAR core, sample select control, reference generator and a 16 word conversion-and-control buffer.
 - Conversion-and-control buffer allows up to 16 independent ADC samples to be converted and stored without any CPU intervention
- ADC12 features include
 - Greater than 200 ksps maximum conversion rate
 - Monotonic 12-bit converter with no missing codes
 - Sample-and-hold with programmable sampling periods controlled by software or timers.
 - Conversion initiation by software, Timer_A, or Timer_B
 - Software selectable on-chip reference voltage generation (1.5 V or 2.5 V)
 - Software selectable internal or external reference
 - Eight individually configurable external input channels
 - Conversion channels for internal temperature sensor, AVCC, and external references
 - Independent channel-selectable reference sources for both positive and negative references
 - Selectable conversion clock source
 - Single-channel, repeat-single-channel, sequence, and repeat-sequence conversion modes
 - ADC core and reference voltage can be powered down separately
 - Interrupt vector register for fast decoding of 18 ADC interrupts
 - 16 conversion-result storage registers

ADC12 Block Diagram

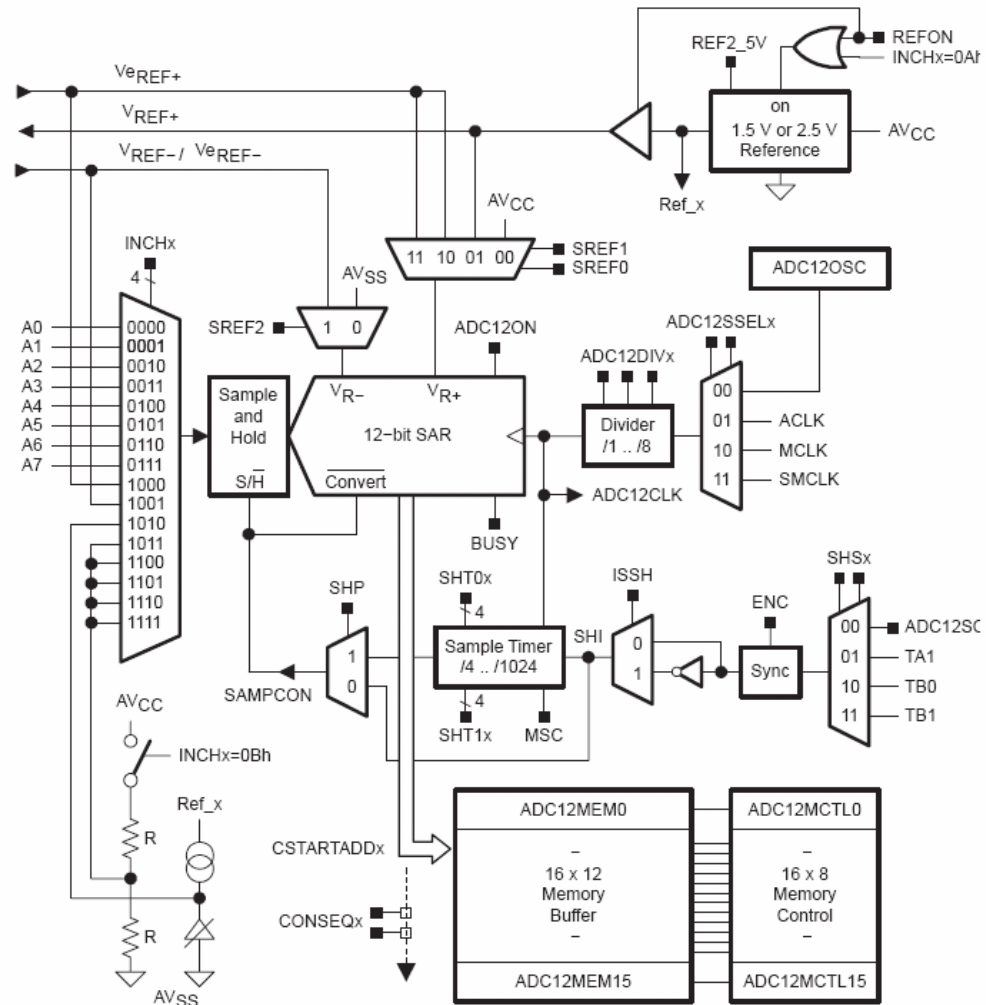



ADC Core

- Core converts an analog input to its 12-bit digital representation and stores the result in conversion memory; the conversion formula is

$$N_{ADC} = 4095 \cdot \frac{V_{in} - V_{R-}}{V_{R+} - V_{R-}}$$

- V_{R+} and V_{R-} are programmable voltage levels: the upper (V_{R+}) and lower limits (V_{R-}) of the conversion
- The digital output (N_{ADC}) is full scale
 - (0FFFh) when the input signal is equal to or higher than V_{R+}
 - 0h when the input signal is equal to or lower than V_{R-}
 - The input channel and the reference voltage levels (V_{R+} and V_{R-}) are defined in the conversion-control memory.

Core Configuration

- Two control registers, ADC12CTL0 and ADC12CTL1
- The core is enabled with the ADC12ON bit
 - The ADC12 can be turned off when not in use to save power
- With few exceptions the ADC12 control bits can only be modified when ENC = 0
 - ENC must be set to 1 before any conversion can take place

ADC12CTL0, ADC12 Control Register 0

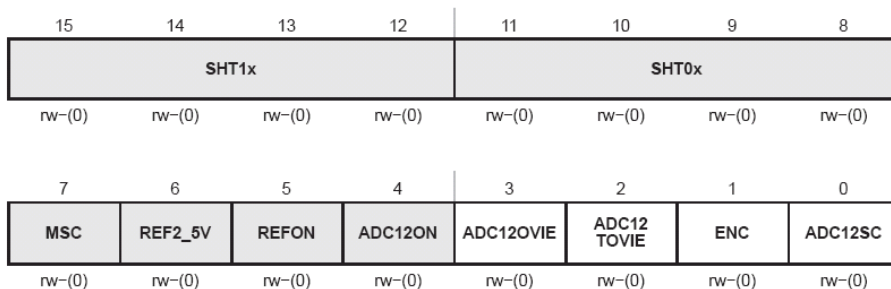

Modifiable only when ENC = 0

ADC12CTL1, ADC12 Control Register 1

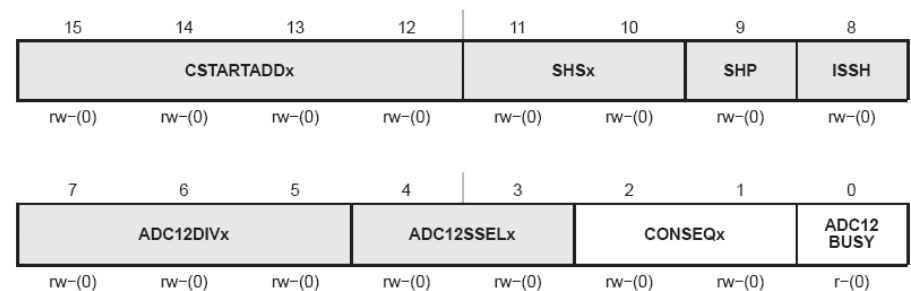

Modifiable only when ENC = 0



Conversion Clock Selection

- ADC12CLK is used both as the conversion clock and to generate the sampling period when the pulse sampling mode is selected
- Source clock selection
 - ADC12SSELx bits to select a source: SMCLK, MCLK, ACLK, and the internal oscillator ADC12OSC
 - The ADC12OSC, generated internally, is in the 5-MHz range, but varies with individual devices, supply voltage, and temperature
 - See the device-specific datasheet for the ADC12OSC specification
 - Source clock can be divided from 1-8 using the ADC12DIVx bits
 - The user must ensure that the clock chosen for ADC12CLK remains active until the end of a conversion. If the clock is removed during a conversion, the operation will not complete and any result will be invalid

ADC12 Inputs

- The eight external and four internal analog signals are selected as the channel for conversion by the analog input multiplexer
- The input multiplexer is a break-before-make type to reduce input-to-input noise injection resulting from channel switching as shown below

Figure 17-2. Analog Multiplexer

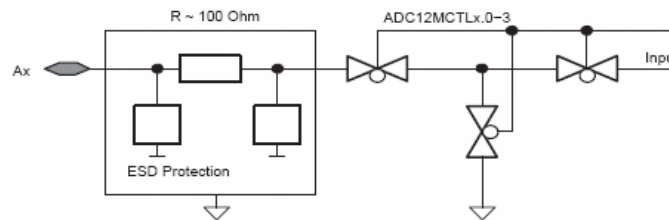

- Port selection
 - ADC12 inputs are multiplexed with the port P6 pins, which are digital CMOS gates
 - Parasitic current problem
 - When analog signals are applied to digital CMOS gates, parasitic current can flow from VCC to GND. This parasitic current occurs if the input voltage is near the transition level of the gate.
 - Disabling the port pin buffer eliminates the parasitic current flow and therefore reduces overall current consumption. The P6SELx bits provide the ability to disable the port pin input and output buffers



Voltage Reference Generator

- Built-in voltage reference with two selectable voltage levels, 1.5 V and 2.5 V
 - Either may be used internally (REFON=1) and externally on pin VREF+
 - When REF2_5V = 1, the internal reference is 2.5 V
 - When REF2_5V = 0, the reference is 1.5 V
 - The reference can be turned off to save power when not in use
 - For proper operation the internal voltage reference generator must be supplied with storage capacitance across VREF+ and AVSS. The recommended storage capacitance is a parallel combination of 10- μ F and 0.1- μ F capacitors
 - From turn-on, a minimum of 17 ms must be allowed for the voltage reference generator to bias the recommended storage capacitors.
- External references may be supplied for V_{R+} and V_{R-} through pins $V_{e_{REF+}}$ and $V_{e_{REF-}}/V_{e_{REF-}}$ respectively



Auto Power-down

- Designed for low power applications
 - When the ADC12 is not actively converting, the core is automatically disabled and automatically re-enabled when needed.
 - The ADC12OSC is also automatically enabled when needed and disabled when not needed.
- The reference is not automatically disabled, but can be disabled by setting $REFON = 0$. When the core, oscillator, or reference are disabled, they consume no current



Sample Timing

- An analog-to-digital conversion is initiated with a rising edge of the sample input signal SHI
- The source for SHI is selected with the SHSx bits and includes the following:
 - The ADC12SC bit
 - The Timer_A Output Unit 1
 - The Timer_B Output Unit 0
 - The Timer_B Output Unit 1
- The polarity of the SHI signal source can be inverted with the ISSH bit.
- The SAMPCON signal controls the sample period and start of conversion. When SAMPCON is high, sampling is active. The high-to-low SAMPCON transition starts the analog-to-digital conversion, which requires 13 ADC12CLK cycles.
- Two different sample-timing methods are defined by control bit SHP, extendedsample mode and pulse mode.

Extended Sample Mode

- Selected when SHP = 0
- The SHI signal directly controls SAMPCON and defines the length of the sample period t_{sample}
 - When SAMPCON is high, sampling is active
 - The high-to-low SAMPCON transition starts the conversion after synchronization with ADC12CLK

Figure 17-3. Extended Sample Mode

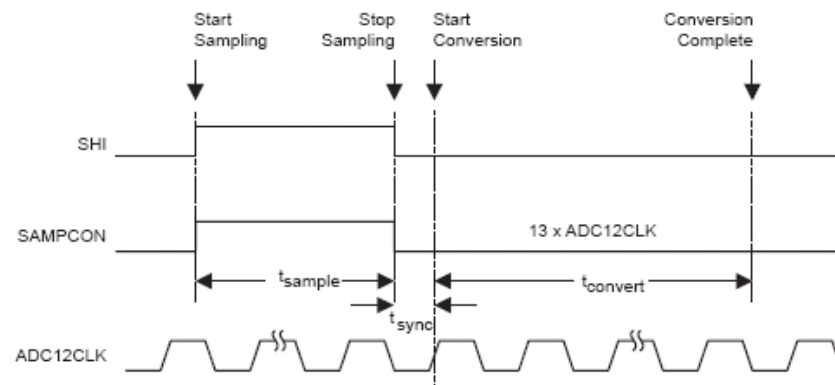

Pulse Sample Mode

- Selected when SHP = 1
- The SHI signal is used to trigger the sampling timer
- The SHT0x and SHT1x bits in ADC12CTL0 control the interval of the sampling timer that defines the SAMPCON sample period t_{sample} .
- The sampling timer keeps SAMPCON high after synchronization with AD12CLK for a programmed interval t_{sample} . The total sampling time is t_{sample} plus t_{sync} .
- The SHTx bits select the sampling time in 4x multiples of ADC12CLK. SHT0x selects the sampling time for ADC12MCTL0 to 7 and SHT1x selects the sampling time for ADC12MCTL8 to 15.

Figure 17-4. Pulse Sample Mode

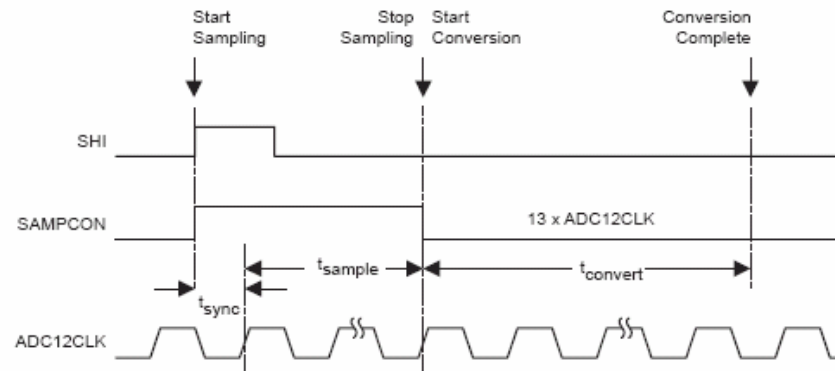

Sample Time Consideration

- When SAMPCON = 0 all Ax inputs are high impedance
- When SAMPCON = 1, the selected Ax input can be modeled as an RC low-pass filter during the sampling time t_{sample} (see below)
- An internal MUX-on input resistance R_I (max. 2 k Ω) in series with capacitor C_I (max. 40 pF) is seen by the source. The capacitor C_I voltage V_C must be charged to within 1 LSB of the source voltage V_S for an accurate 12-bit conversion
 - $t_{\text{sample}} > (R_S + R_I) \ln(2^{13}) C_I + 800 \text{ ns}$
 - $t_{\text{sample}} > (R_S + 2 \text{ k}) 9.011 \times 40 \text{ pF} + 800 \text{ ns}$;
if R_S is 10 k Ω , t_{sample} must be greater than 5.13 μs .

Figure 17-5. Analog Input Equivalent Circuit

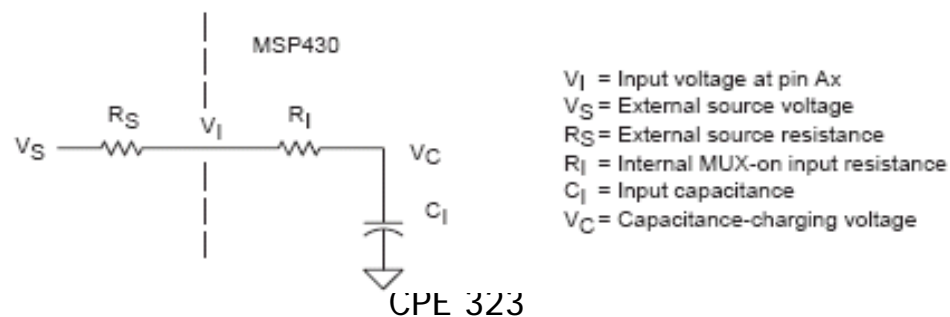

Conversion Memory

- 16 ADC12MEMx conversion memory registers to store conversion results

ADC12MEMx, ADC12 Conversion Memory Registers

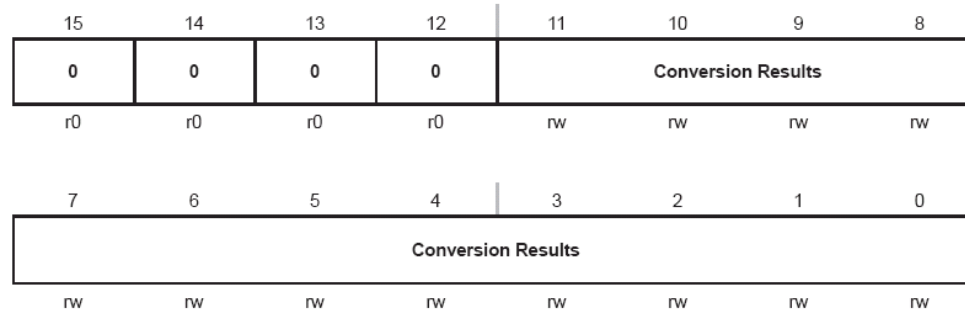

- Each ADC12MEMx is configured with an associated ADC12MCTLx control register

ADC12MCTLx, ADC12 Conversion Memory Control Registers

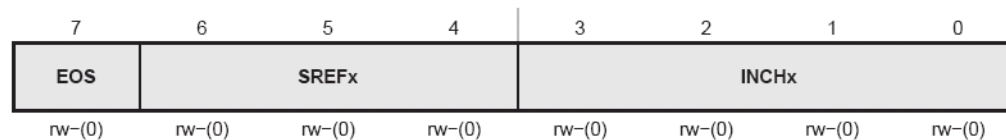



Conversion Memory (cont'd)

- SREFx bits define the voltage reference
- INCHx bits select the input channel
- EOS bit defines the end of sequence when a sequential conversion mode is used
 - A sequence rolls over from ADC12MEM15 to ADC12MEM0 when the EOS bit in ADC12MCTL15 is not set
- CSTARTADDx bits define the first ADC12MCTLx used for any conversion
 - If the conversion mode is single-channel or repeat-single-channel the CSTARTADDx points to the single ADC12MCTLx to be used
 - If the conversion mode selected is either sequence-of-channels or repeat-sequence-of-channels, CSTARTADDx points to the first ADC12MCTLx location to be used in a sequence.
- A pointer, not visible to software, is incremented automatically to the next ADC12MCTLx in a sequence when each conversion completes. The sequence continues until an EOS bit in ADC12MCTLx is processed - this is the last control byte processed.
- When conversion results are written to a selected ADC12MEMx, the corresponding flag in the ADC12IFGx register is set



Conversion Modes

- Determined by CONSEQx bits

CONSEQx	Mode	Operation
00	Single channel single-conversion	A single channel is converted once.
01	Sequence-of-channels	A sequence of channels is converted once.
10	Repeat-single-channel	A single channel is converted repeatedly.
11	Repeat-sequence-of-channels	A sequence of channels is converted repeatedly.

Single-Channel, Single Conversion Mode

- A single channel is sampled and converted once
- The ADC result is written to the ADC12MEMx defined by the CSTARTADDx bits.
- When ADC12SC triggers a conversion, successive conversions can be triggered by the ADC12SC bit.
- When any other trigger source is used, ENC must be toggled between each conversion.

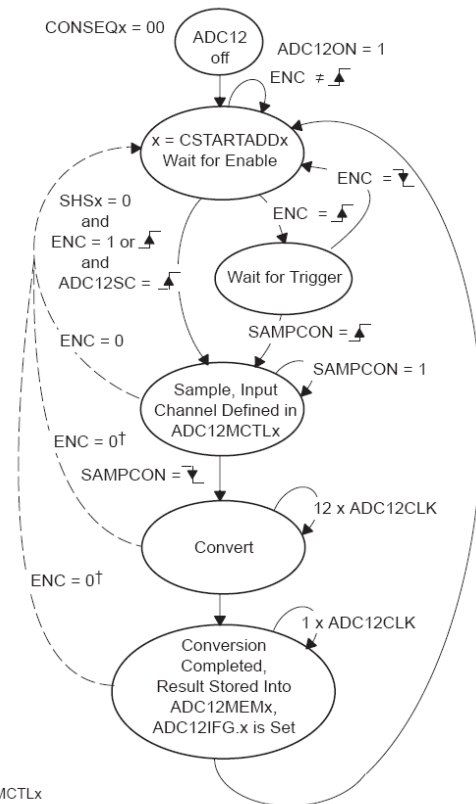

x = pointer to ADC12MCTLx
 †Conversion result is unpredictable

Repeat-Single-Channel Mode

- A single channel is sampled and converted continuously.
- The ADC results are written to the ADC12MEMx defined by the CSTARTADDx bits.
 - It is necessary to read the result after the completed conversion because only one ADC12MEMx memory is used and is overwritten by the next conversion.

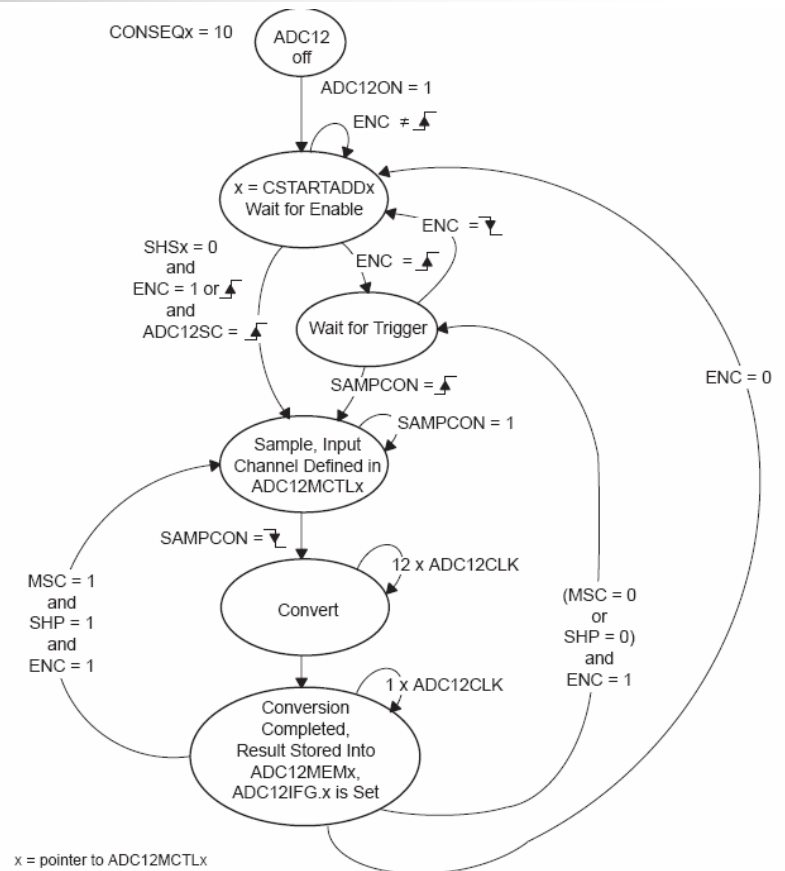

Repeat-Sequence-of-Channels Mode

- A sequence of channels is sampled and converted repeatedly.
- The ADC results are written to the conversion memories starting with the ADC12MEMx defined by the CSTARTADDx bits.
- The sequence ends after the measurement of the channel with a set EOS bit and the next trigger signal re-starts the sequence.

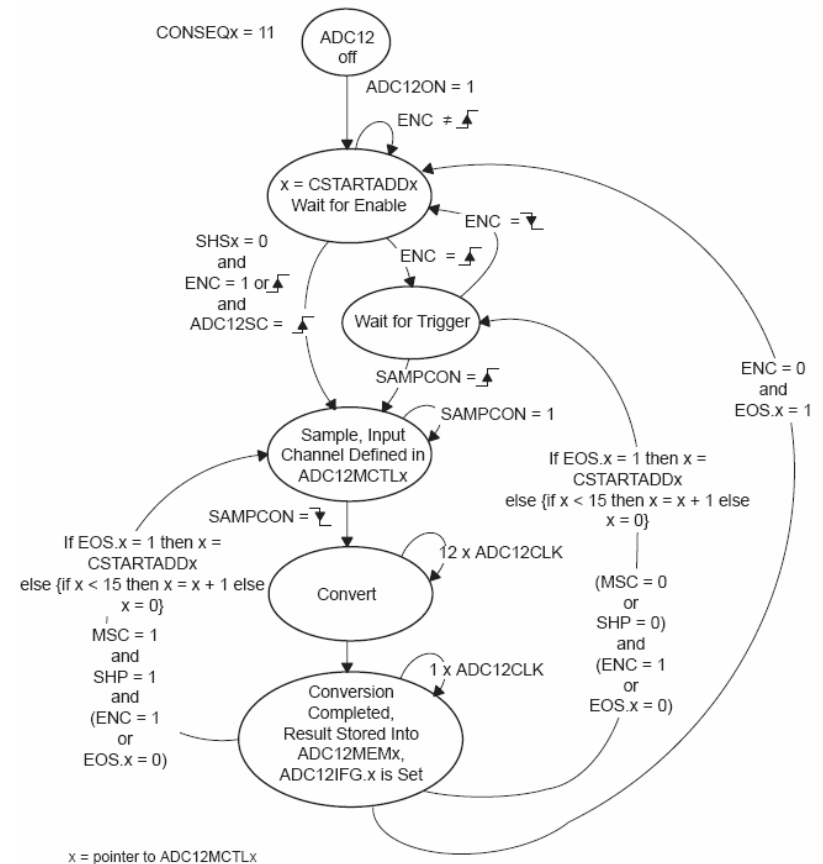



Using the Multiple Sample and Convert (MSC) Bit

- Perform successive conversions automatically and as quickly as possible, a multiple sample and convert function is available
- When $MSC = 1$, $CONSEQx > 0$, and the sample timer is used, the first rising edge of the SHI signal triggers the first conversion.
- Successive conversions are triggered automatically as soon as the prior conversion is completed.
 - Additional rising edges on SHI are ignored until the sequence is completed in the single-sequence mode or until the ENC bit is toggled in repeat-single-channel, or repeated-sequence modes.
 - The function of the ENC bit is unchanged when using the MSC bit.



Stopping Conversions

- Depends on the mode of operation.
- Recommended ways to stop an active conversion or conversion sequence are
 - Resetting ENC in single-channel single-conversion mode stops a conversion immediately and the results are unpredictable.
 - For correct results, poll the busy bit until reset before clearing ENC.
 - Resetting ENC during repeat-single-channel operation stops the converter at the end of the current conversion.
 - Resetting ENC during a sequence or repeat-sequence mode stops the converter at the end of the sequence.
 - Any conversion mode may be stopped immediately by setting the $CONSEQx = 0$ and resetting ENC bit. Conversion data are unreliable.

Temperature On-Chip Sensor

- Select INCHx = 1010
- Typical transfer function (check device specific datasheet)
- The sample period must be greater than 30 μ s.
- Selecting the temperature sensor automatically turns on the on-chip reference generator as a voltage source for the temperature sensor
 - However, it does not enable the VREF+ output or affect the reference selections for the conversion.
 - The reference choices for converting the temperature sensor are the same as with any other channel.

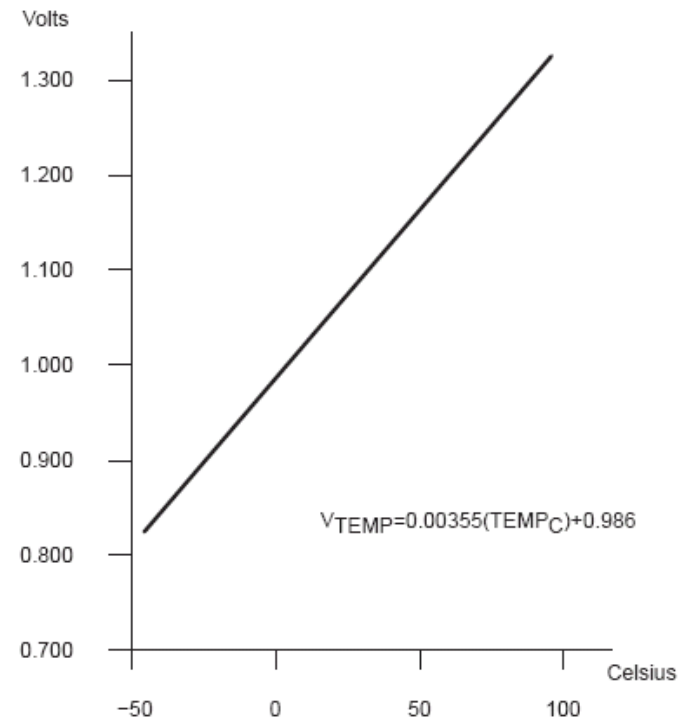

ADC Grounding and Noise Considerations

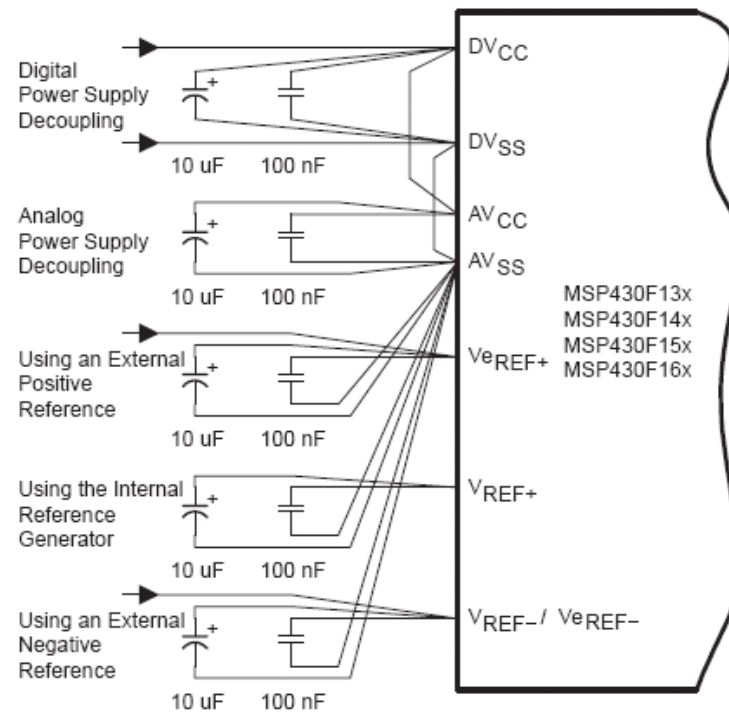



ADC Interrupts

- The ADC12 has 18 interrupt sources:
 - ADC12IFG0-ADC12IFG15
 - ADC12OV, ADC12MEMx overflow
 - ADC12TOV, ADC12 conversion time overflow
- The ADC12IFGx bits are set when their corresponding ADC12MEMx memory register is loaded with a conversion result.
 - An interrupt request is generated if the corresponding ADC12IE_x bit and the GIE bit are set.
- The ADC12OV condition occurs when a conversion result is written to any ADC12MEMx before its previous conversion result was read
- The ADC12TOV condition is generated when another sample-and-conversion is requested before the current conversion is completed.

Interrupt Handling Routine

- The ADC12IV value is added to the PC to automatically jump to the appropriate routine.
 - The numbers at the right margin show the necessary CPU cycles for each instruction.
 - The software overhead for different interrupt sources includes interrupt latency and return-from-interrupt cycles, but not the task handling itself
 - The latencies are:
 - ADC12IFG0 - ADC12IFG14, ADC12TOV and ADC12OV 16 cycles
 - ADC12IFG15 14 cycles
 - The interrupt handler for ADC12IFG15 shows a way to check immediately if a higher prioritized interrupt occurred during the processing of ADC12IFG15.
- This saves nine cycles if another ADC12 interrupt is pending.

```
; Interrupt handler for ADC12.
INT_ADC12          ; Enter Interrupt Service Routine      6
  ADD    &ADC12IV,PC; Add offset to PC                  3
  RETI   ; Vector 0: No interrupt                       5
  JMP    ADOV      ; Vector 2: ADC overflow              2
  JMP    ADTOV     ; Vector 4: ADC timing overflow       2
  JMP    ADM0      ; Vector 6: ADC12IFG0                 2
  ...           ; Vectors 8-32                          2
  JMP    ADM14     ; Vector 34: ADC12IFG14              2
;
; Handler for ADC12IFG15 starts here. No JMP required.
;
ADM15  MOV  &ADC12MEM15,xxx; Move result, flag is reset
      ...           ; Other instruction needed?
      JMP  INT_ADC12  ; Check other int pending
;
; ADC12IFG14-ADC12IFG1 handlers go here
;
ADM0   MOV  &ADC12MEM0,xxx ; Move result, flag is reset
      ...           ; Other instruction needed?
      RETI   ; Return                                     5
;
ADTOV  ...           ; Handle Conv. time overflow
      RETI   ; Return                                     5
;
ADOV   ...           ; Handle ADCMEMx overflow
      RETI   ; Return                                     5
```

An Example: ADC12, Single Sample

```
*****
//MSP430xG461x Demo - ADC12, Sample A0, Set P5.1 if A0 > 0.5*AVcc
//
//Description: A single sample is made on A0 with reference to AVcc.
//Software sets ADC12SC to start sample and conversion - ADC12SC
//automatically cleared at EOC. ADC12 internal oscillator times sample (16x)
// and conversion. In Mainloop MSP430 waits in LPM0 to save power until ADC12
// conversion complete, ADC12_ISR will force exit from LPM0 in Mainloop on
// reti. If A0 > 0.5*AVcc, P5.1 set, else reset.
// ACLK = 32kHz, MCLK = SMCLK = default DCO 1048576Hz, ADC12CLK = ADC12OSC
//
//          MSP430xG461x
//          -----
//          /|\|          XIN|-
//          | |          | 32kHz
//          --RST        XOUT|-
//          |            |
//          Vin -->|P6.0/A0   P5.1|--> LED
//
// A. Dannenberg/ M. Mitchell
// Texas Instruments Inc.
// October 2006
// Built with CCE Version: 3.2.0 and IAR Embedded Workbench Version: 3.41A
//*****
#include "msp430xG46x.h"
```

```
void main(void)
{
    WDTCTL = WDTPW + WDTHOLD; // Stop WDT
    ADC12CTL0 = SHT0_2 + ADC12ON; // Sampling time, ADC12 on
    ADC12CTL1 = SHP; // Use sampling timer
    ADC12IE = 0x01; // Enable interrupt
    ADC12CTL0 |= ENC;
    P6SEL |= 0x01; // P6.0 ADC option select
    P5DIR |= 0x02; // P5.1 output

    while (1)
    {
        ADC12CTL0 |= ADC12SC; // Start sampling/conversion
        __bis_SR_register(LPM0_bits + GIE);
        // LPM0, ADC12_ISR will force exit
    }
}

#pragma vector = ADC12_VECTOR
__interrupt void ADC12_ISR(void)
{
    if (ADC12MEM0 >= 0x7ff) // ADC12MEM = A0 > 0.5AVcc?
        P5OUT |= 0x02; // P5.1 = 1
    else
        P5OUT &= ~0x02; // P5.1 = 0

    __bic_SR_register_on_exit(LPM0_bits); // Exit LPM0
}
```



DAC12





DAC12 Introduction

- 12-bit, voltage output DAC.
 - The DAC12 can be configured in 8-bit or 12-bit mode and may be used in conjunction with the DMA controller
 - When multiple DAC12 modules are present, they may be grouped together for synchronous update operation.
- Features of the DAC12 include:
 - 12-bit monotonic output
 - 8-bit or 12-bit voltage output resolution
 - Programmable settling time vs power consumption
 - Internal or external reference selection
 - Straight binary or 2s compliment data format
 - Self-calibration option for offset correction
 - Synchronized update capability for multiple DAC12s

DAC12 Block Diagram

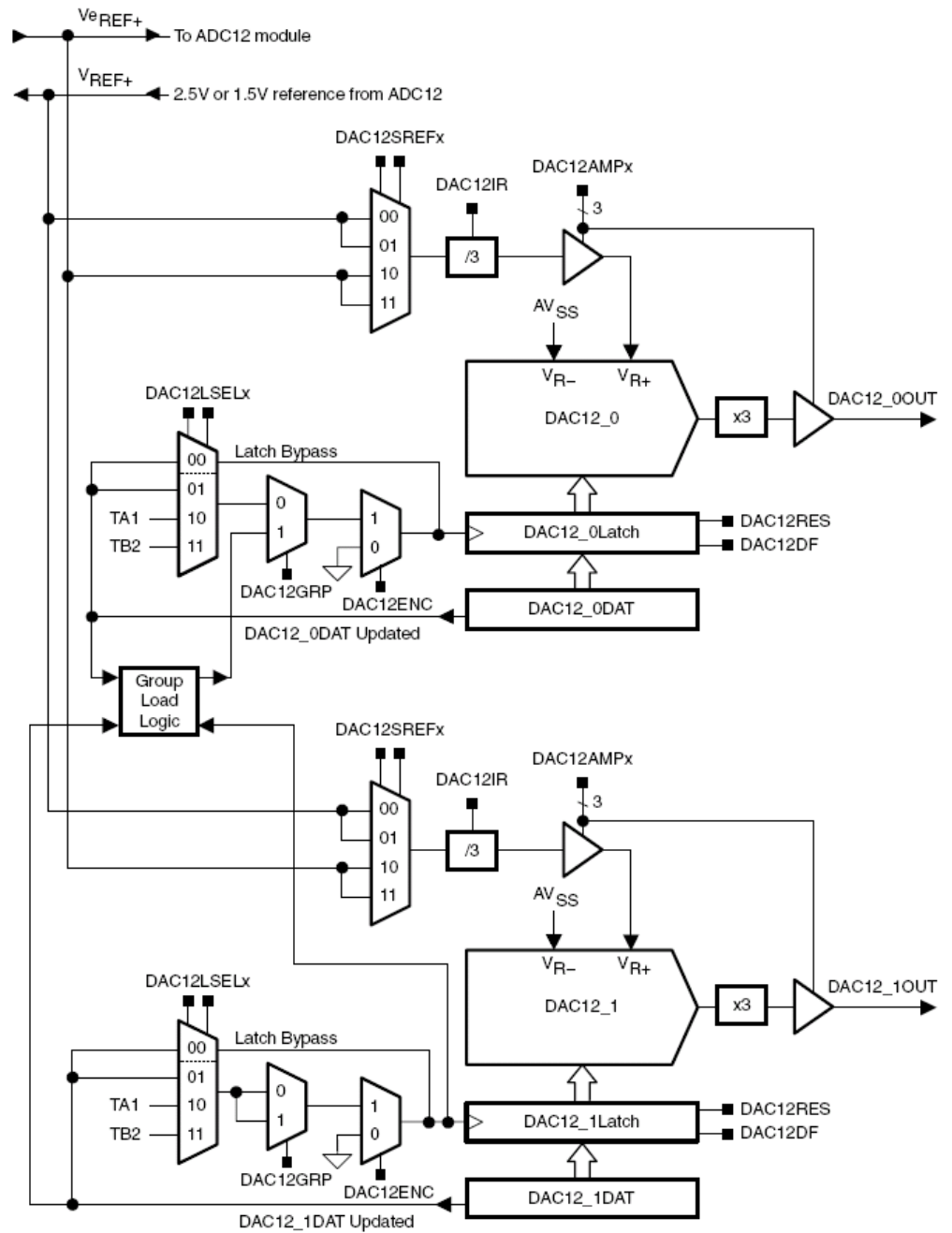



DAC12 Core

- DAC12RES
 - 0 – 12-bit
 - 1 – 8-bit
- DAC12IR
 - 0 – 3x
 - 1 – 1x

Resolution	DAC12RES	DAC12IR	Output Voltage Formula
12 bit	0	0	$V_{out} = V_{ref} \times 3 \times \frac{DAC12_xDAT}{4096}$
12 bit	0	1	$V_{out} = V_{ref} \times \frac{DAC12_xDAT}{4096}$
8 bit	1	0	$V_{out} = V_{ref} \times 3 \times \frac{DAC12_xDAT}{256}$
8 bit	1	1	$V_{out} = V_{ref} \times \frac{DAC12_xDAT}{256}$



DAC12 Port Selection

- DAC12 outputs are multiplexed with the port P6 pins and ADC12 analog inputs, and also the VeREF+ and P5.1/S0/A12 pins
 - When $\text{DAC12AMP}_x > 0$, the DAC12 function is automatically selected for the pin, regardless of the state of the associated PxSEL_x and PxDIR_x bits.
- The DAC12OPS bit selects between the P6 pins and the VeREF+ and P5.1 pins for the DAC outputs.
 - For example, when $\text{DAC12OPS} = 0$, DAC12_0 outputs on P6.6 and DAC12_1 outputs on P6.7.
 - When $\text{DAC12OPS} = 1$, DAC12_0 outputs on VeREF+ and DAC12_1 outputs on P5.1.
 - See the port pin schematic in the device-specific datasheet for more details.



DAC12 Reference

- On MSP430FG43x and MSP430FG461x devices, the reference for the DAC12 is configured to use either an external reference voltage or the internal 1.5-V/2.5-V reference from the ADC12 module with the DAC12SREFx bits
- When DAC12SREFx = {0,1} the VREF+ signal is used as the reference and when DAC12SREFx = {2,3} the VeREF+ signal is used as the reference
- To use an ADC internal reference, it must be enabled and configured via the applicable ADC control bits.
- DAC12 voltage output buffers
 - Reference input and voltage output buffers of the DAC12 can be configured for optimized settling time vs power consumption
 - Eight combinations are selected using the DAC12AMPx bits.
 - In the low/low setting, the settling time is the slowest, and the current consumption of both buffers is the lowest.
 - The medium and high settings have faster settling times, but the current consumption increases.
 - See the device-specific data sheet for parameters.



Updating the DAC12 Voltage Output

- DAC12_xDAT register can be connected directly to the DAC12 core or
- double buffered.
- The trigger for updating the DAC12 voltage output is selected with the DAC12LSELx bits.
 - When DAC12LSELx = 0 the data latch is transparent and the DAC12_xDAT register is applied directly to the DAC12 core. The DAC12 output updates immediately when new DAC12 data is written to the DAC12_xDAT register, regardless of the state of the DAC12ENC bit.
 - When DAC12LSELx = 1, DAC12 data is latched and applied to the DAC12 core after new data is written to DAC12_xDAT.
 - When DAC12LSELx = 2 or 3, data is latched on the rising edge from the Timer_A CCR1 output or Timer_B CCR2 output respectively. DAC12ENC must be set to latch the new data when DAC12LSELx > 0.

DAC12_xDAT Data Format

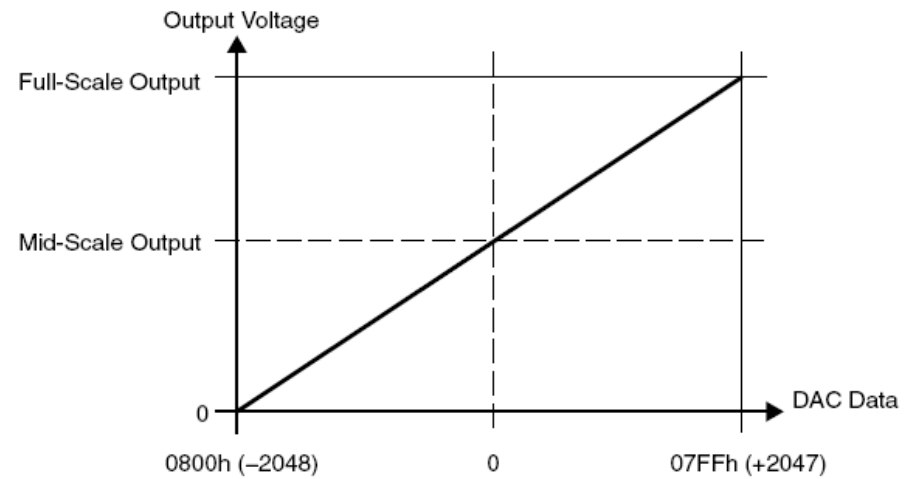
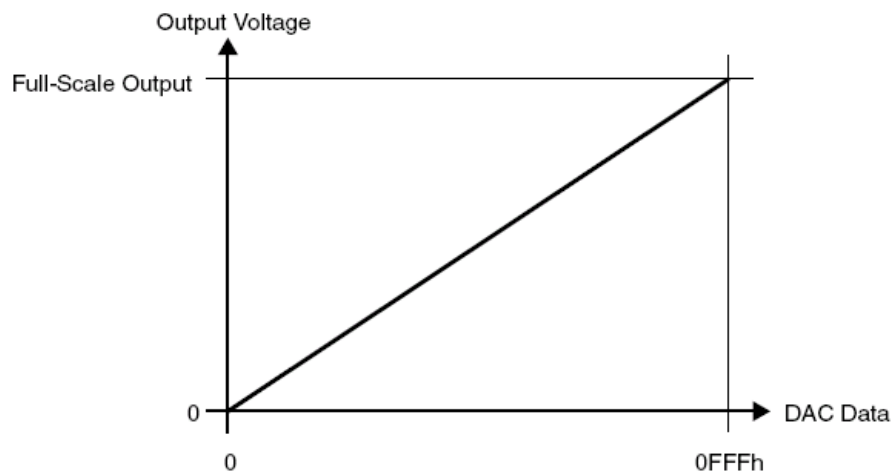

Offset Calibration

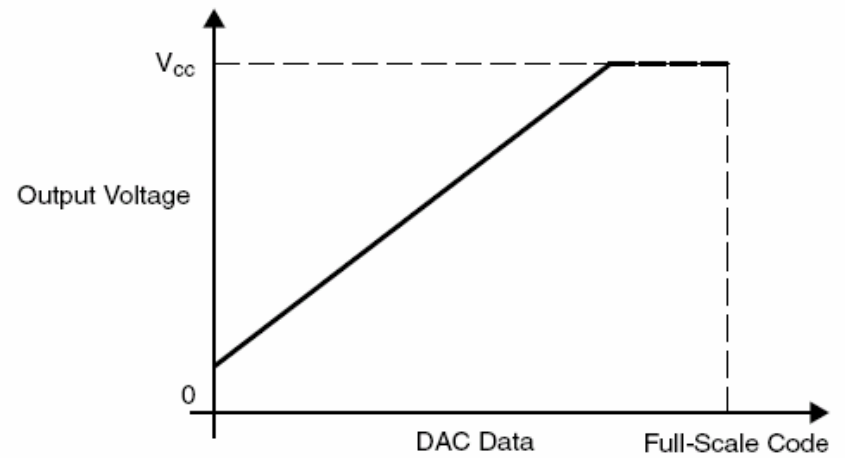
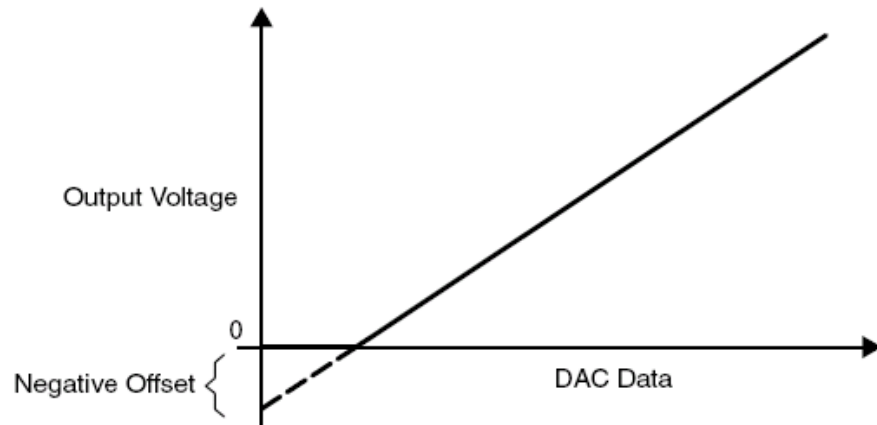

DAC12 Group Update

