

**CPE/EE 422/522**  
**Spring 2004**  
**Chapter 5 - Digital Design**  
**with SM Charts**

**Dr. Rhonda Kay Gaede**



**5.1 State Machine Charts**

¥ State graphs used to describe state machines controlling a digital system

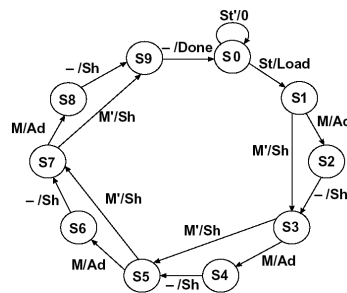
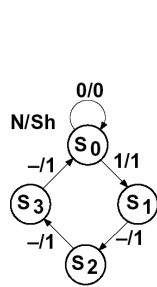

¥ Alternative: use state machine flowchart

## 5.1 State Machine Charts

---

- ¥ SM chart or ASM (*Algorithmic State Machine*) chart
- ¥ Easier to understand the operation of digital system by examination of the SM chart instead of equivalent state graph
- ¥ SM chart leads directly to hardware realization

## 5.1 State Machine Charts - Components

---

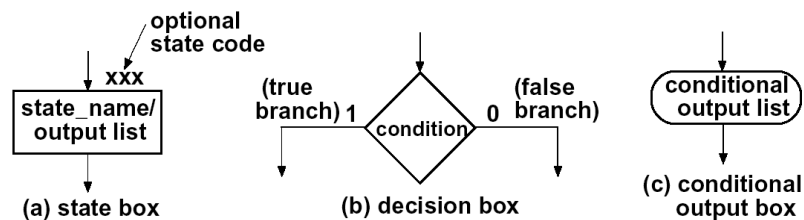

### 5.1 State Machine Charts - SM Blocks

SM chart is constructed from SM blocks

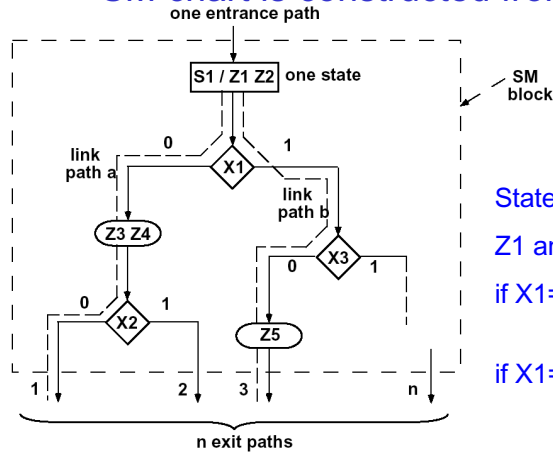

State S1 is entered =>  
 Z1 and Z2 become 1  
 if X1=0  
     Z3 and Z4 become 1  
 if X1=1 and X3=0  
     Z5 become 1

Spring 2004 Slide #5

### 5.1 State Machine Charts - Equivalent SM Blocks

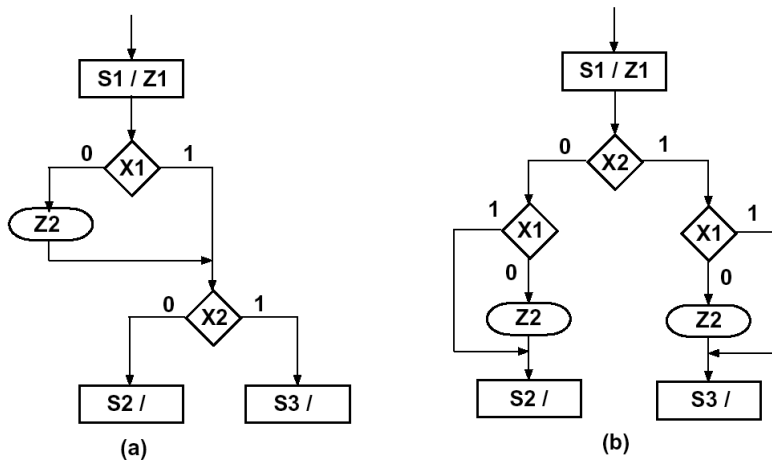

Spring 2004 Slide #6

### 5.1 State Machine Charts - Equivalent SM Charts for Combinational Networks

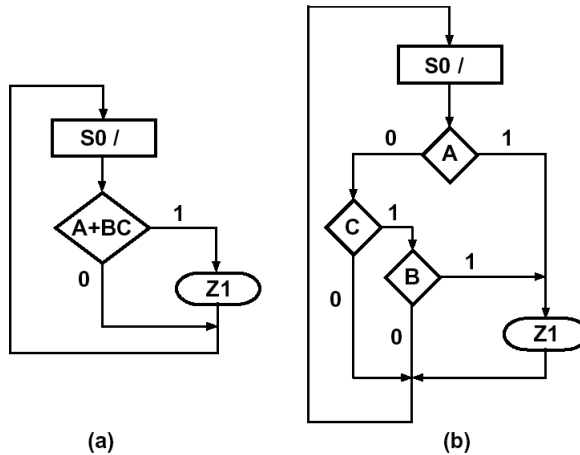

### 5.1 State Machine Charts - Block with Feedback

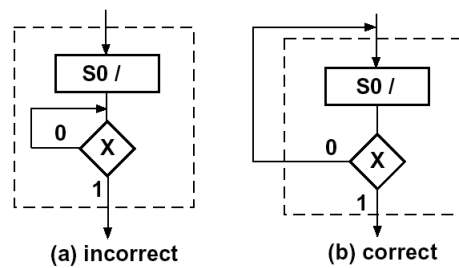

### 5.1 State Machine Charts - Equivalent SM Blocks

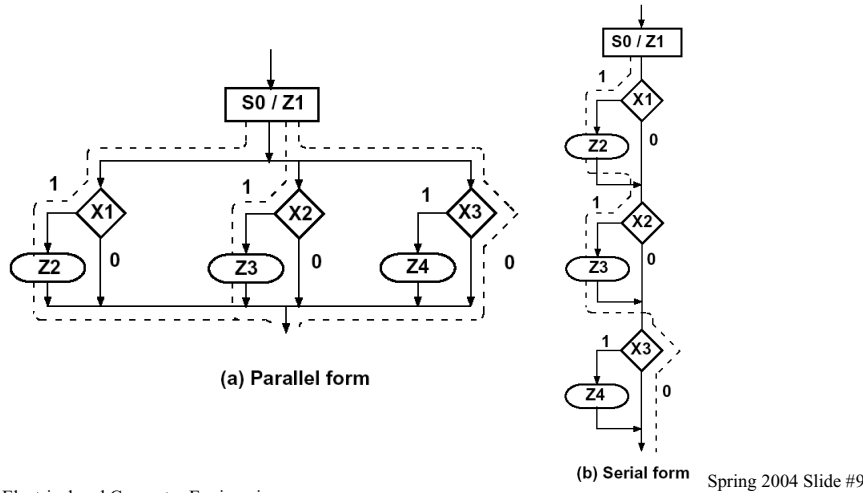

### 5.1 State Machine Charts - Converting a State Graph to an SM Chart

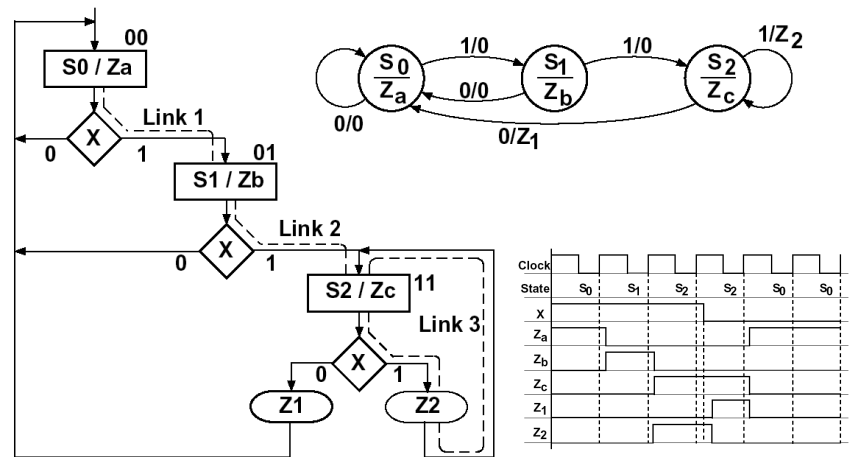

## 5.2 Derivation of SM Charts - SM Chart for Binary Multiplier

