

**The University of Alabama in Huntsville**  
**ECE Department**  
**EE 202 – 02**  
**Fall 2010**  
**Test 2 Solution**

1. (1 point) A prime implicant is a product term obtained by combining the maximum possible number of adjacent squares in the map.
2. (1 point) Unspecified minterms of a function are called don't cares conditions.
3. (1 point) The NOR operation is the dual of the NAND operation.
4. (1 point) A full adder is a combinational circuit that forms the arithmetic sum of three bits.
5. (1 point) A multiplexer is a combinational circuit that selects binary information from one of many input lines and directs it to a single output line.
6. (15 points) Simplify the following function and implement it with two-level NOR gates:

$$\begin{aligned}
 F(w, x, y, z) &= wx' + y'z' + w'yz' \\
 F' &= w'z + xz + wxy \\
 F &= (w'z + xz + wxy)' \\
 &= (w'z)'(xz)'(wxy)' \\
 &= (w + z')(x' + z')(w' + x' + y')
 \end{aligned}$$

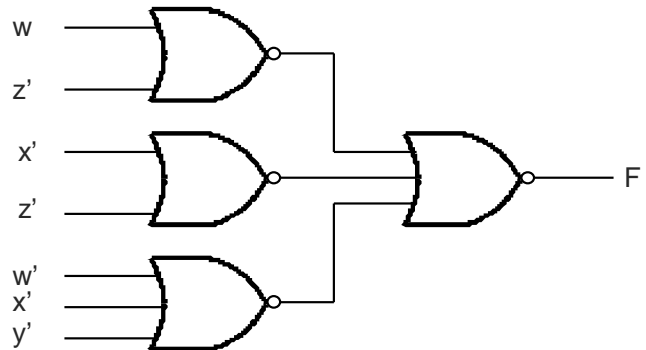
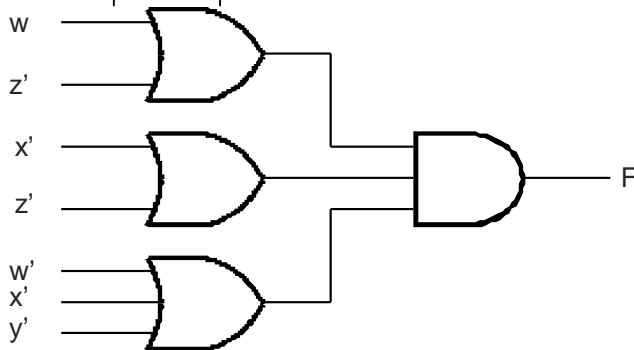
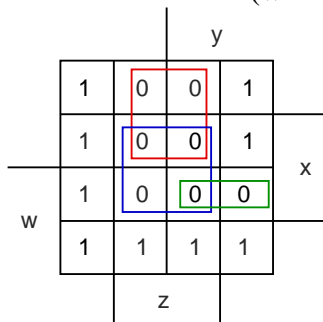

7. (20 points) Design a code converter that converts a decimal digit from the 8,4, -2, -1 code to BCD. You do not have to draw a circuit diagram.

C3	C2	C1	C0	B3	B2	B1	B0	C3	C2	C1	C0	B3	B2	B1	B0
0	0	0	0	0	0	0	0	0	0	0	0	0	0	0	0
0	1	1	1	0	0	0	1	0	0	0	1	d	d	d	d
0	1	1	0	0	0	1	0	0	0	1	0	d	d	d	d
0	1	0	1	0	0	1	1	0	0	1	1	d	d	d	d
0	1	0	0	0	1	0	0	0	1	0	0	0	1	0	0
1	0	1	1	0	1	0	1	0	1	0	1	0	0	1	1
1	0	1	0	0	1	1	0	0	1	1	0	0	0	1	0
1	0	0	1	0	1	1	1	1	0	1	1	1	0	0	1
1	0	0	0	1	0	0	0	1	0	0	0	1	0	0	0
1	1	1	1	1	0	0	1	1	0	0	1	0	1	1	1
0	0	0	1	d	d	d	d	1	0	1	0	0	1	1	0
0	0	1	0	d	d	d	d	1	0	1	1	0	1	0	1
0	0	1	1	d	d	d	d	1	1	0	0	d	d	d	d
1	1	0	0	d	d	d	d	1	1	0	1	d	d	d	d
1	1	0	1	d	d	d	d	1	1	1	0	d	d	d	d
1	1	1	0	d	d	d	d	1	1	1	1	1	0	0	1

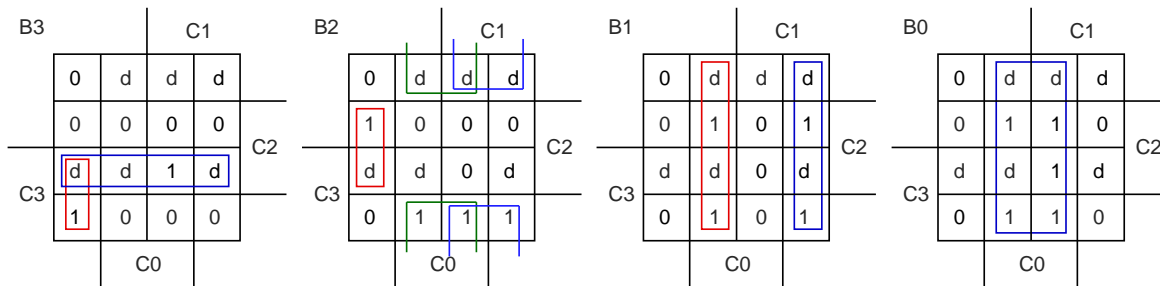

$$B3 = C3C2 + C3C1'C0'$$

$$B2 = C2'C1 + C2'C0 + C2C1'C0'$$

$$B1 = C1C0' + C1'C0$$

$$B0 = C0$$

8. (10 points) Simplify the following Boolean expression, using three variable maps:  
 $F(x, y, z) = xy + x'y'z' + x'yz'$

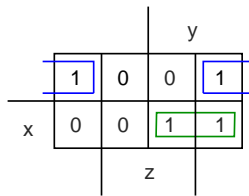

$$F(x, y, z) = xy + x'z'$$

9. (10 points) Simplify the following Boolean function, using three-variable maps:  
 $F(x, y, z) = \Sigma(0, 1, 3, 4, 5)$

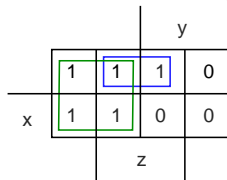

$$F = y' + x'z$$

10. (15 points) Construct a 5-to-32 line decoder with as many 2-to-4 line decoders with enable and any additional logic that you might need. Use block diagrams for the components.

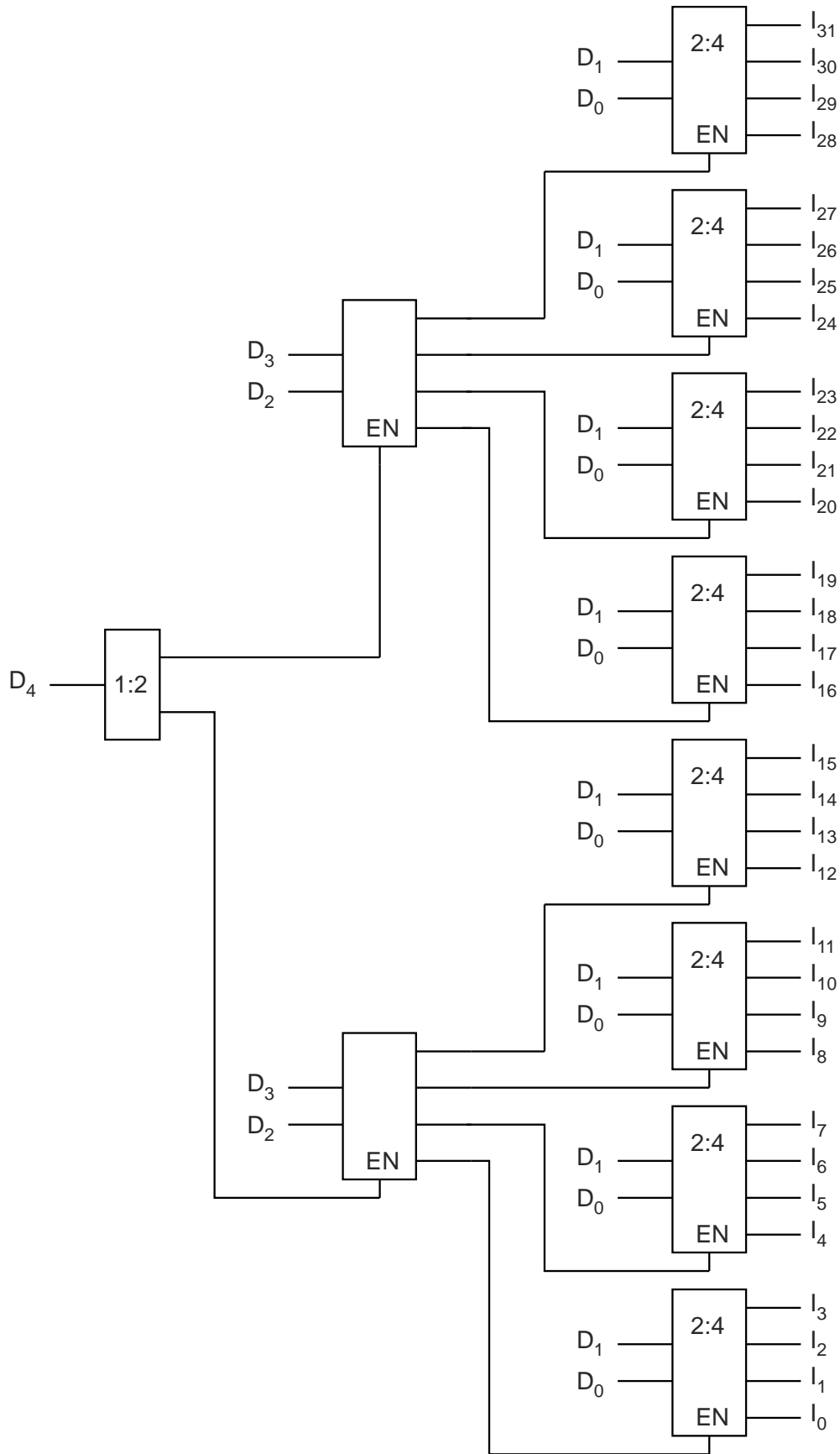

11. (10 points) Construct a  $32 \times 1$  multiplexer with as many  $8 \times 1$  multiplexers and any additional logic that you might need. Use block diagrams for the components.

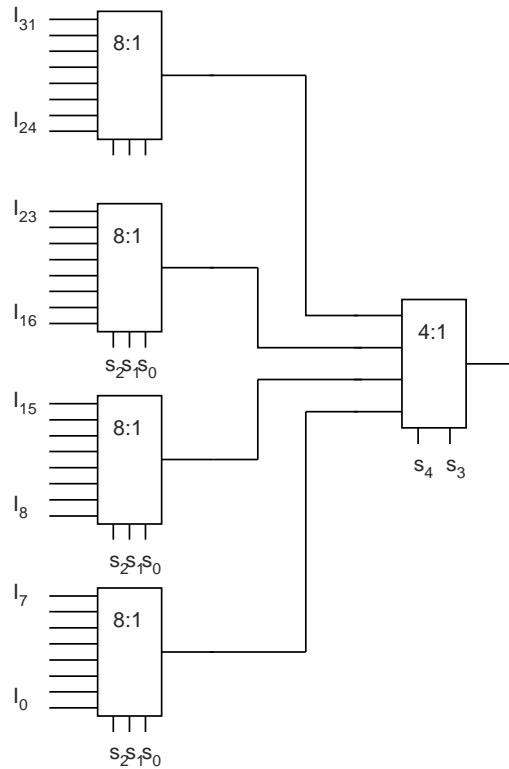

12. (15 points) If the delays in the circuit below are as given in the table, find the propagation delays from the inputs to C and V.

Logic Element	Propagation Delay
Inverter	30 ps
AND/NAND	50 ps
OR/NOR	60 ps
XOR	80 ps
Full Adder	150 ps

